

HD Camera Adaptor

Operating Instructions

Before operating the unit, please read this manual thoroughly and retain it for future reference.

CA-FB70

WARNING

To reduce the risk of fire or electric shock, do not expose this apparatus to rain or moisture.

To avoid electrical shock, do not open the cabinet. Refer servicing to qualified personnel only.

CAUTION

Danger of explosion if battery is incorrectly replaced.

Replace only with the same or equivalent type recommended by the manufacturer.

When you dispose of the battery, you must obey the law in the relative area or country.

IMPORTANT

The nameplate is located on the bottom.

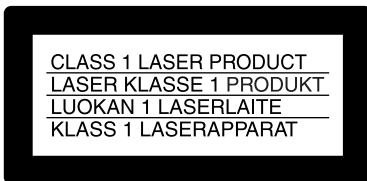

This HD Camera Adaptor is classified as a CLASS 1 LASER PRODUCT.

Caution

Use of controls or adjustments or performance of procedures other than those specified herein may result in hazardous radiation exposure.

Caution

The use of optical instruments with this product will increase eye hazard.

For the customers in the U.S.A.

This equipment has been tested and found to comply with the limits for a Class A digital device, pursuant to Part 15 of the FCC Rules. These limits are designed to provide reasonable protection against harmful interference when the equipment is operated in a commercial environment. This equipment generates, uses, and can radiate radio frequency energy and, if not installed and used in accordance with the instruction manual, may cause harmful interference to radio communications. Operation of this equipment in a residential area is likely to cause harmful interference in which case the user will be required to correct the interference at his own expense.

You are cautioned that any changes or modifications not expressly approved in this manual could void your authority to operate this equipment.

All interface cables used to connect peripherals must be shielded in order to comply with the limits for a digital device pursuant to Subpart B of Part 15 of FCC Rules.

This device complies with Part 15 of the FCC Rules. Operation is subject to the following two conditions: (1) this device may not cause harmful interference, and (2) this device must accept any interference received, including interference that may cause undesired operation.

For the customers in Canada

This Class A digital apparatus complies with Canadian ICES-003.

For the customers in Europe

This product with the CE marking complies with the EMC Directive issued by the Commission of the European Community.

Compliance with this directive implies conformity to the following European standards:

- EN55103-1: Electromagnetic Interference (Emission)
- EN55103-2: Electromagnetic Susceptibility (Immunity)

This product is intended for use in the following Electromagnetic Environments: E1 (residential), E2 (commercial and light industrial), E3 (urban outdoors), E4 (controlled EMC environment, ex. TV studio).

For the customers in Europe

The manufacturer of this product is Sony Corporation, 1-7-1 Konan, Minato-ku, Tokyo, 108-0075 Japan. The Authorized Representative for EMC and product safety is Sony Deutschland GmbH, Hedelfinger Strasse 61, 70327 Stuttgart, Germany. For any service or guarantee matters please refer to the addresses given in separate service or guarantee documents.

Table of Contents

Overview	5
Features	5
Names and Functions of Parts	7
System Configuration	11
Preparation and Setting	14
Attaching the Adaptor to a Camera/Camcorder	14
Connecting a Camera Control Unit (CCU)	15
Attaching the Accessory Shoe Kit	16
Outputting Trunk Signal	17
Using an Intercom	17
Starting the System	18
Setting the System Format	18
Error Messages	20
Important Notes on Operation	21
Specifications	22
General	22
Connectors	22
Supplied Accessories	22
Other peripheral devices	23
Pin assignment	23

Overview

The CA-FB70 HD Camera Adaptor is a camera adaptor that can be attached to the HXC-D70 HD Color Camera or PMW-500/350/320 Solid-State Memory Camcorder. By connecting to the HXCU-FB70 HD Camera Control Unit (CCU) via an optical fiber cable, high-quality video signals can be transmitted over a long distance between the adaptor and CCU.

Can be installed on the following camera/camcorder

- HXC-D70 series
 - PMW-500 series ¹⁾
 - PMW-350 series ²⁾
 - PMW-320 series ²⁾
- 1) An optional CBK-HD02 SDI/ COMPOSITE Input and 50 Pin Interface is required.
 - 2) An optional CBK-CE01 50 Pin Interface and Digital Extender is required.

Features

Cable-free connection to camera/camcorder

The adaptor can be installed on the attachment shoe of a camera/camcorder, allowing for connection of input and output signals or power supplies via the 50 pin interface and BATT interface. As no cables are necessary for attachment, the adaptor offers a solution for solid camera-system configuration.

Long distance transmission via optical fiber cable

- To connect the HXCU-FB70 HD Camera Control Unit to the adaptor, either a single-mode optical fiber cable or optical composite cable can be used.
- When you use an optical composite cable to supply power to the adaptor and camera/camcorder from the HXCU-FB70 HD Camera Control Unit, the connection distance can be extended up to 250 m (820 ft) ¹⁾. When you use a single-mode optical fiber cable and mains to supply power to the adaptor and camera/camcorder, the connection distance can be extended up to 10 km (32,800 ft) ²⁾.
- While the HXCU-FB70 HD Camera Control Unit and HXCE-FB70 Power Supply Unit are connected by a single-mode optical fiber cable (up to 10 km (32,800 ft))²⁾, you can connect the adaptor and HXCE-FB70 with an optical composite cable to supply power (up to 250 m (820 ft))¹⁾. The adaptor offers flexibility to configure the camera system to suit your usage environment.

- 1) The available distance for power supply varies depending on the total power consumption of the connected camera/camcorder, lens, accessories, etc. For details, see the operating instructions of the device that supplies power.
- 2) The maximum extension distance depends on the characteristic of the cable and the number of connected cables.

Two ways to supply power

Power can be supplied to the adaptor or the connected camera/camcorder in the following ways: ① Via an optical composite cable, or ② Via the DC IN connector of the adaptor.

Support for live camera system operation

The adaptor is equipped with the following features and input/output connectors to allow for live broadcasting, not only with the HXC-D70 but with standalone camcorders.

- Intercom feature (2 switchable lines; engineer or producer line)
- Tally lamp (red and green)
- Call feature
- Return signal feature (up to selectable 4 lines)
- Prompter output

Names and Functions of Parts

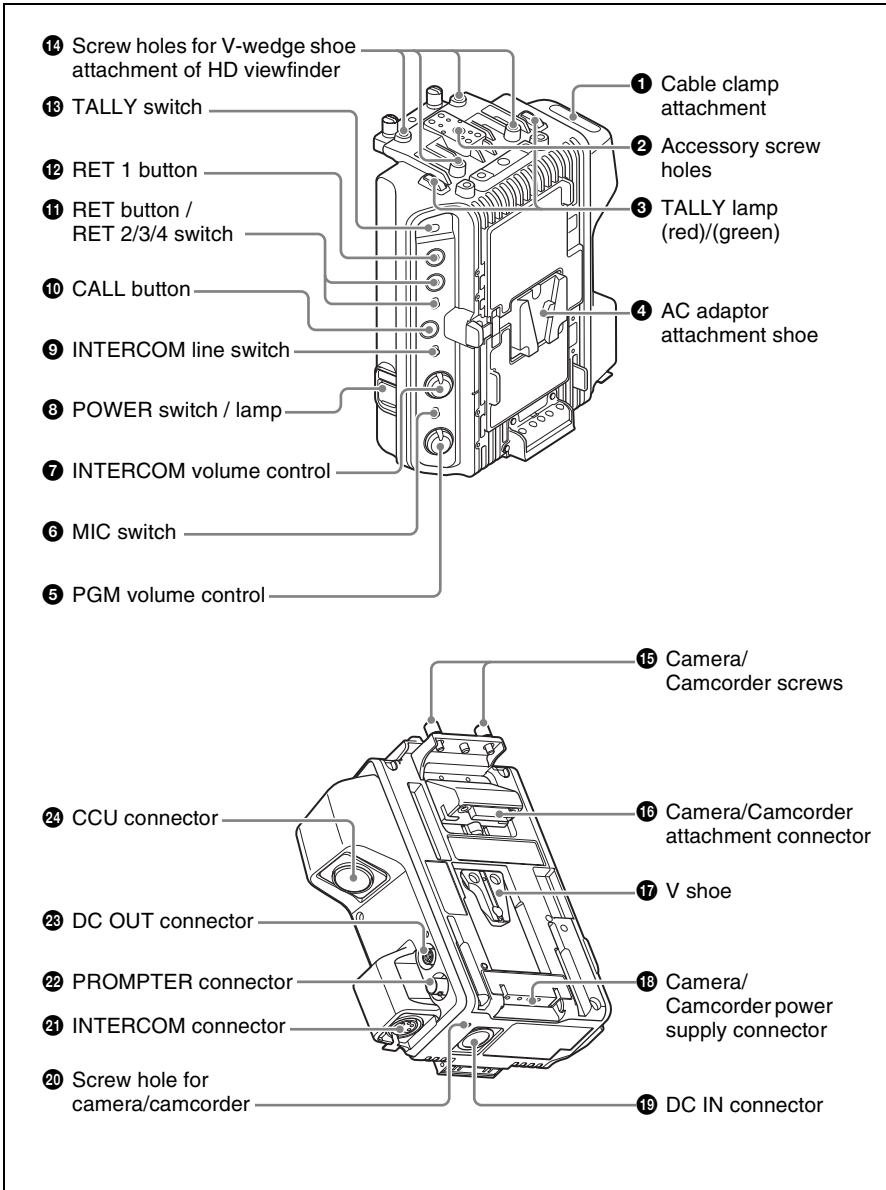

1 Cable clamp attachment

Attaches the supplied cable clamp belt.

2 Accessory screw holes

These comprise of a U1/4"-20 screw hole to secure an accessory, four screw holes to secure the supplied accessory fitting shoe (for the DXF-C50WA Electronic Viewfinder), and four screw holes to secure the optional cold shoe kit (X-2546-633-).

3 TALLY lamp (red)/(green)

When the TALLY switch is set to ON, the TALLY lamp lights to indicate that a tally signal is input to the connected camera control unit or a call signal is generated by pressing the CALL button. When the TALLY switch is set to OFF, the lamp does not light.

4 AC adaptor attachment shoe

You can attach the AC-DN2B/DN10 AC Adaptor to supply power to the adaptor.

5 PGM (program) volume control

Adjusts the program audio listening level.

6 MIC (intercom mic) switch

Turns on or off output of intercom audio signals. Set to ON when you talk to a CCU or external system.

7 INTERCOM volume control

Adjusts the volume level of the headset connected to the INTERCOM connector.

8 POWER switch / lamp

Set to ON to turn on the adaptor and set to OFF to turn off. When the adaptor is turned off, power will not be supplied to the connected camera/camcorder. When the adaptor is turned on, the Power lamp lights (green).

9 INTERCOM line switch

Selects the talk line.

PROD: To talk over the producer line.

ENG: To talk over the engineer line.

Note

When the adaptor is connected to the HXC-D70 HD Color Camera, the intercom of HXC-D70 becomes available. In this case, you can select the intercom line (PROD/ENG) of HXC-D70 by the INTERCOM line switch of the adaptor.

10 CALL button

When this button is pressed, the red CALL lamp on the front panel of a CCU or external controlling device (RCP/RM, etc.) will light.

11 RET button / RET 2/3/4 switch

When using return video 1 and other line simultaneously, the return video signal selected with the RET 2/3/4 switch is displayed on the viewfinder screen while the RET button is pressed.

12 RET 1 button

The return video 1 signal from the camera control unit is monitored on the viewfinder screen while this button is pressed.

Notes

- If you press both the RET 1 button and RET button (RET 2/3/4), the RET 1 button takes priority.
- When the adaptor is connected to the PMW-500/350/320 Solid-State Memory Camcorder, if you change the return video signal, the previously selected return signal may be displayed for a moment in the viewfinder.
- When the adaptor is connected to the PMW-500/350/320 Solid-State Memory Camcorder, if you press the RET button to switch the displayed picture, the picture in the viewfinder may be distorted for a moment. This is not a malfunction.

13 TALLY switch

Set to ON when you use the TALLY lamp.

14 Screw holes for V-wedge shoe attachment of HD viewfinder

These are V-wedge shoe attachment for HD viewfinder screw holes (4) for M4 screws to secure an HD monitor.

15 Camera/Camcorder screws

Screws to secure the adaptor to the camera/camcorder.

16 Camera/Camcorder connector (50-pin)

Connect to the adaptor connector of the camera or the camera adaptor connector of the camcorder (requires installation of an optional interface) to send and receive video and audio signals.

17 V shoe

This is a V shoe for attachment of this adaptor to a camera/camcorder.

18 Camera/Camcorder power supply connector

Supplies power to the camera/camcorder.

19 DC IN connector (XLR 4-pin, male)

When operating the adaptor using an external DC power supply, connect an optional DC power cable to this connector, then connect the cable to the DC output connector of a battery charger, such as the BC-L70, BC-L160, etc.

For information on pin assignment, see "DC IN" in "Pin assignment" on page 24.

20 Screw hole for camera/camcorder

A screw hole to fix the camera or camcorder. Use the screws for CA bracket.

21 INTERCOM connector (XLR 5-pin)

Used for input and output of intercom audio signals if an XLR 5-pin headset is connected.

For information on pin assignment, see "INTERCOM" in "Pin assignment" on page 23.

22 PROMPTER connector (BNC)

For output of the VBS prompter signal when a CCU is connected.

23 DC OUT connector (4-pin, female)

Supplies power to external devices such as script lights. (Up to 1.5 A)

For information on pin assignment, see "DC OUT" in "Pin assignment" on page 24.

24 CCU connector (optical multi-fiber connector)

Connects the adaptor to the HXCU-FB70 HD Camera Control Unit. When you use an optical composite cable for connection, power supply, all camera signals, such as control signal, video signal and audio signal, can be transmitted. When you use only single-mode optical fiber cable for connection, all signals (except power supply) can be transmitted by a pair of optical fiber cables.

For information on pin assignment, see "CCU" in "Pin assignment" on page 24.

System Configuration

Connection using optical composite cable

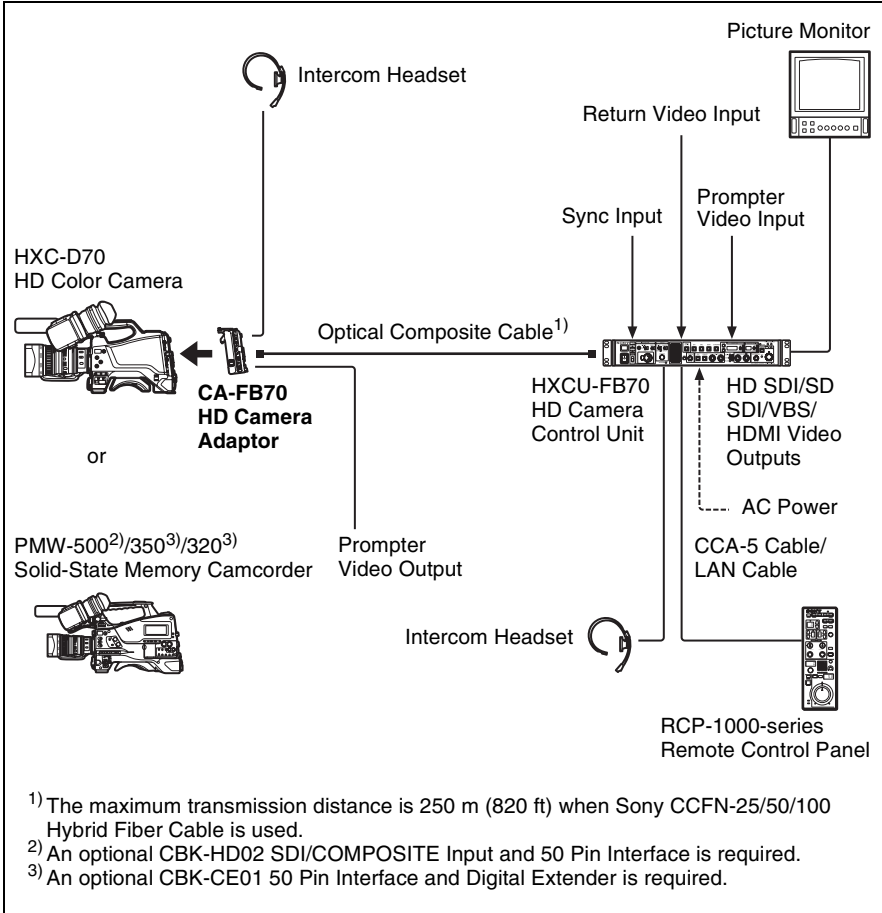

Connection using single-mode optical fiber cable only

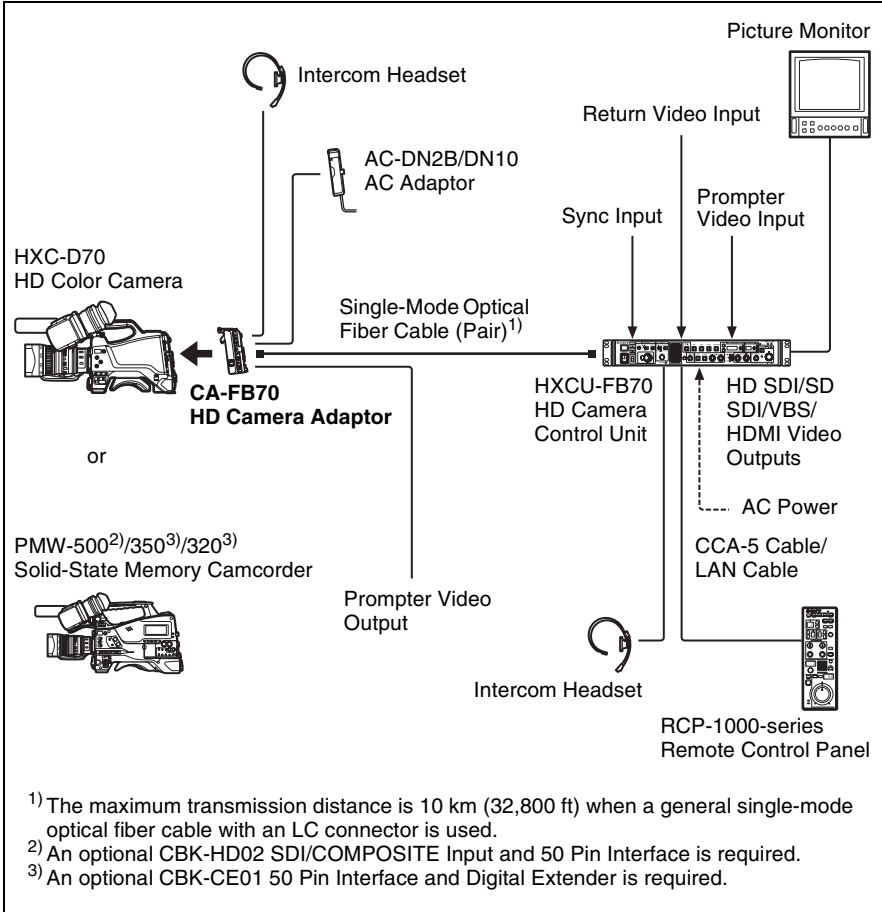

Connection using the HXCE-FB70 Power Supply Unit

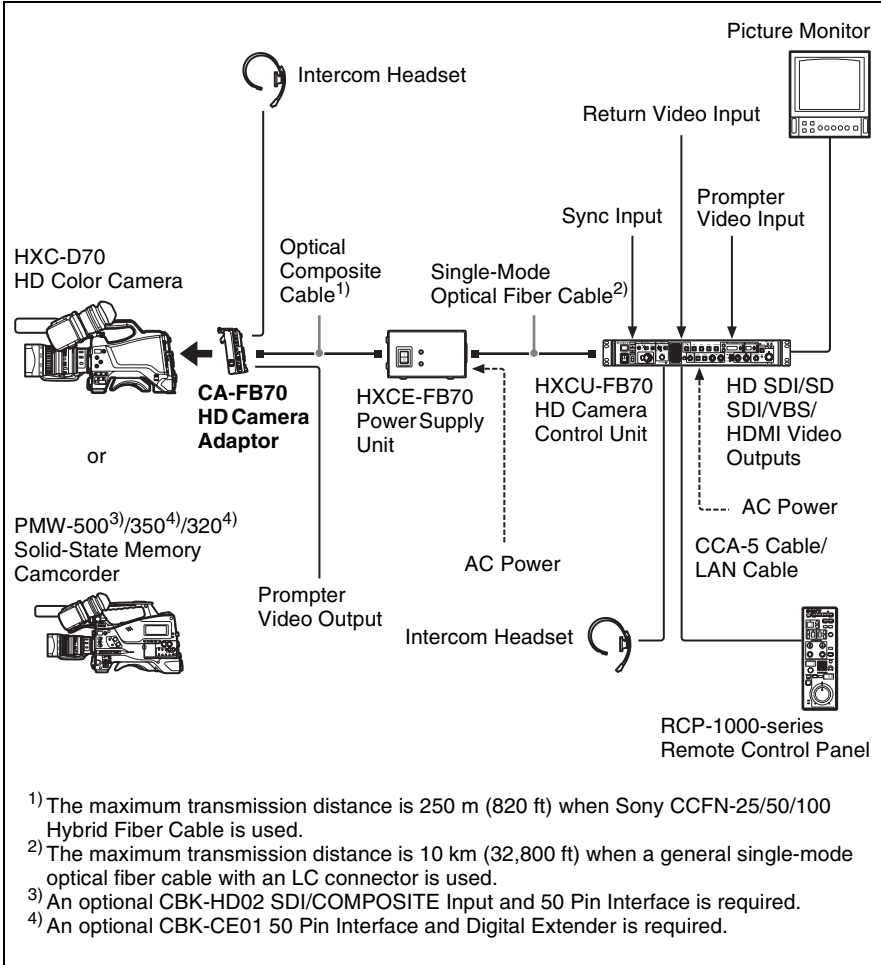

Preparation and Setting

Attaching the Adaptor to a Camera/Camcorder

- 1 Loosen the screws on the 50P cover of the camera or camcorder, then remove it.
- 2 Fix the supplied CA bracket on the battery attachment shoe of the camera or camcorder using the two screws.

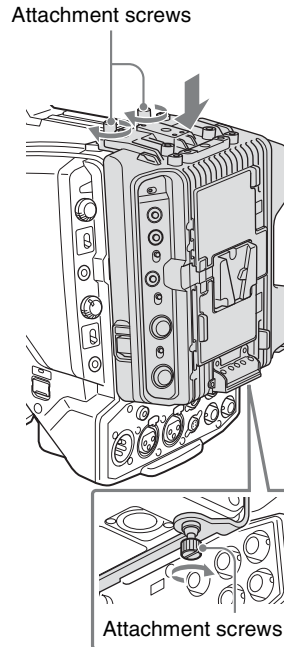
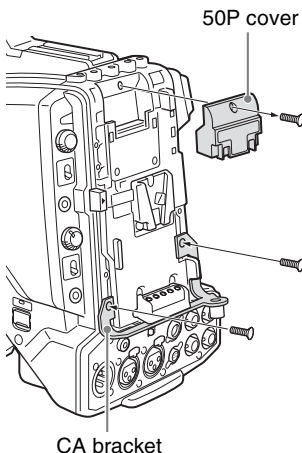

Note

Tighten the screws securely so that the unit will not fall off.

To remove

Perform the installation procedure in reverse, loosening the screws that were tightened then.

- 3 Slide down the adaptor from the upper side of the battery attachment shoe of the camera/camcorder.
- 4 Tighten the attachment screws at the top (2) and lower part (1) of the adaptor.

Connecting a Camera Control Unit (CCU)

When operating the camera in a system with a CCU, connect between the CCU connector of the adaptor and the CAMERA connector of the CCU. When required, secure the cable to the adaptor, using the supplied cable clamp belt.

To use the cable clamp belt

- 1 Insert the belt bracket **Ⓒ** into hole **Ⓐ** or **Ⓑ** of the cable clamp belt.

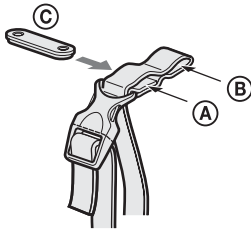

- 2
 - 1 Remove the screw-hole cover on the cable clamp attachment shoe of the adaptor, and
 - 2 secure the cable clamp belt to the adaptor, using the two supplied screws (+B3×10).

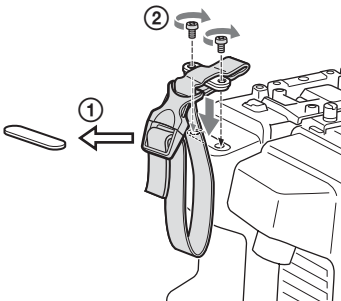

- 3
 - 1 Release the buckle,
 - 2 bundle the cable with the belt,
 - 3 then lock the buckle again.

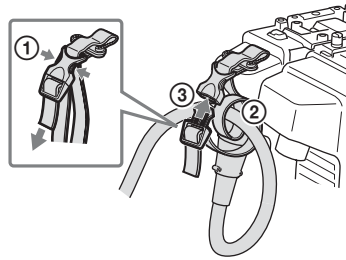

- 4 Adjust the length by pulling down the end of the belt.

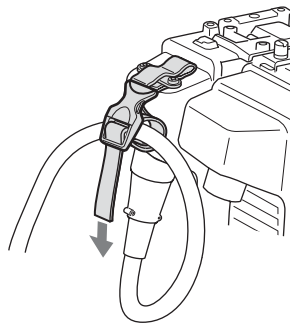

Attaching the Accessory Shoe Kit

When you attach the DXF-51 or DXF-C50WA Electronic Viewfinder, screw the supplied accessory shoe kit to the accessory shoe holes of the adaptor (four holes), then attach the viewfinder to the accessory shoe.

To attach the accessory shoe

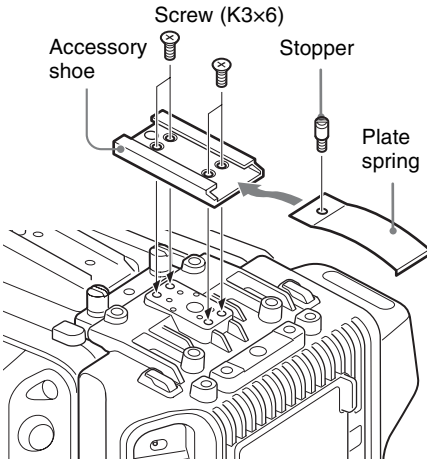

- 1** Attach the accessory shoe using the four screws supplied with the shoe kit (K3x6).
- 2** Slide the plate spring in the direction shown by the arrow and secure the spring using the stopper.

Outputting Trunk Signal

When connected to the HXC-D70 HD Color Camera

You can communicate with an external device that is connected to the TRUNK connector (RS-232C) or REMOTE connector of the HXC-D70, and an external device that is connected to the TRUNK connector of the CCU.

To output trunk signal from the HXC-D70

Configure the following menu (MAINTENANCE menu M13: <TRUNK>) of the HXC-D70.

Configure the setting according to the interface of the connected device.

Menu page	Item	Setting	Description
<TRUNK>	TRUNK	OFF	Disable the trunk signal output
		ON*	Enable the trunk signal output
	Interface	232c*	Outputs from the TRUNK connector via RS-232C I/F
		422a	Outputs from the REMOTE connector via RS-422A I/F

* default setting.

Using an Intercom

You can talk to the CCU operator by attaching an intercom headset to the INTERCOM connector of the adaptor.

When connected to the HXC-D70 HD Color Camera

The INTERCOM connector of the HXC-D70 is also available for communication with the CCU operator. The talk line of the HXC-D70 can be controlled by the INTERCOM line switch of the adaptor.

- Configure the settings of the connected intercom headset in the OPERATION menu of the HXC-D70.

13 <HEAD SET>: Settings for input of the headset's microphone

14 <INTERCOM LEVEL>: Settings for the SIDE TONE level of the headset

The displayed items in the above menu are as follows:

Intercom1 (CAM): Intercom settings of the HXC-D70

Intercom2 (CA): Intercom settings of the adaptor

When you do not use the INTERCOM connector of the HXC-D70, set the INTERCOM ON/OFF switch of the HXC-D70 to OFF.

For details, refer to the operating instructions of the HXC-D70.

Note

When the PMW-500/350/320 Solid-State Memory Camcorder is connected, the microphone input settings for the intercom headset will be fixed at the following (factory default) values:

Dynamic / -60dB / Unbalanced

For information on connection to an intercom system and configuration of the settings, contact your Sony dealer.

Starting the System

- 1 Attach the adaptor to the camera/camcorder, then connect the adaptor to the CCU using an optical composite cable.
- 2 Set the POWER switch of the adaptor and camera/camcorder to ON, then set the POWER switch of the CCU to ON. Power will be supplied to the adaptor from the CCU and the adaptor turns on. The adaptor then supplies power to the camera/camcorder, which turns on.

While the system is starting up, the POWER lamp (green) blinks at 0.5 Hz. When the communication for certification between the adaptor and camera/camcorder completes, the POWER lamp (green) lights.

Note

When the POWER switch of the connected camera/camcorder is set to OFF, or when the camera/camcorder does not start normally, the POWER lamp (green) keeps blinking at 0.5 Hz.

Setting the System Format

To record/output with the system, it is necessary to set the video format for the camera/camcorder, adaptor and CCU.

The adaptor supports the following video formats.

- 1920×1080/59.94i
- 1280×720/59.94P
- 1920×1080/50i
- 1280×720/50P

The video format setting of the adaptor is synchronized with that of the CCU.

① When connected to the HXC-D70 HD Color Camera

Both the video format setting of the adaptor and HXC-D70 are synchronized with that of the CCU (HXCU-FB70).

② When connected to the PMW-500/350/320 Solid-State Memory Camcorder

As PMW-500/350/320 supports video formats that the adaptor and CCU do not, the video format setting of the camcorder is not synchronized with those of the CCU. Set the video format of the camcorder according to the video format setting of the CCU.

Solid-State Memory Camcorder PMW-500/350/320		Video format of the adaptor and CCU
Mode	Video format	
HD mode (HD SDI output)	1920×1080/59.94i	1920×1080/59.94i
	1280×720/59.94P	1280×720/59.94P
	1920×1080/50i	1920×1080/50i
	1280×720/50P	1280×720/50P
	1920×1080/29.97PsF	Do not support
	1920×1080/25PsF	
	1920×1080/23.98PsF	
SD mode (SD SDI output)	720×486/59.94i	
	720×576/50i	

Notes

- As the adaptor supports bidirectional transmission of HD digital signals, the adaptor will not operate properly if the camcorder is in the SD mode. Also, when an unsupported video format for the adaptor and CCU is selected or the SDI OUTPUT setting is set to SD in the camcorder, the adaptor will not operate. For information on the mode setting of the camcorder, refer to the operating instructions of the camcorder.
- If video formats are inconsistent between the adaptor and camcorder, the POWER lamp of the adaptor blinks at 2 Hz. For details, see “Error Messages” on page 20.

Error Messages

When an error is detected, an error message shown in the below table appears. Since the adaptor does not have a display, the message is displayed in the menu of the CCU or the remote control panel. The adaptor also alarms it by blinking the POWER lamp (green).

POWER lamp (Green)	Display in the remote control panel	Display in the CCU	Indication
Blinks (2 Hz)	-	-	The video formats are inconsistent between the adaptor/CCU and the camera/camcorder ¹⁾
Blinks (2 Hz)	CHU: RX CARE	CAM: RX OPT CARE	Optical LEVEL is low
Blinks (4 Hz)	CHU: RX WARNING	CAM: RX OPT WARNING	Optical LEVEL is extremely low
Blinks (4 Hz)	-	-	Receiving-end voltage of the CCU connector has dropped

¹⁾ If the video format is inconsistent with the camera/camcorder, video signal output from the CCU may be distorted.

Important Notes on Operation

Use and storage locations

Store in a level, ventilated place. Avoid using or storing the adaptor in the following places.

- In excessive heat or cold. Operating temperature range is -10°C to $+45^{\circ}\text{C}$ (14°F to 113°F). When connected to the camcorder, the operating temperature range is 0°C to 40°C (32°F to 104°F).
- Remember that in summer in warm climates the temperature inside a car with the windows closed can easily exceed 50°C (122°F).
- In damp or dusty locations
- Locations where the adaptor may be exposed to rain
- Locations subject to violent vibration
- Near strong magnetic fields
- Close to radio or TV transmitters producing strong electromagnetic fields.
- In direct sunlight or close to heaters for extended periods

Do not subject to strong shocks

Do not drop the adaptor or subject it to strong shocks. The adaptor may be damaged.

Do not wrap in a cloth or other covering during operation

Internal temperatures may rise, causing malfunctions.

Maintenance

Clean the cabinet and panels by wiping lightly with a soft, dry cloth. If they are very dirty, use a cloth dampened with a small amount of neutral detergent, then wipe dry. Avoid the use of volatile

solvents such as thinners, alcohol, benzene, and insecticides. They may damage the surface finish or cause it to peel off.

Notes when connecting to the HXC-D70 HD Color Camera

When you attach the adaptor to the HXC-D70 HD Color Camera, the following signals are cannot be selected.

Page title	Page No.	Item	Signal
<TEST OUT>	M10	OUTPUT	VBS
<SDI OUT>	M11	OUTPUT	SD-SDI

Notes when connecting to the PMW-500/350/320 Solid-State Memory Camcorder

When you use the PMW-500/350/320 Solid-State Memory Camcorder with the adaptor attached, the following symptoms may occur.

- GATE of the skin signal is not displayed in the CCU output.

When you perform the following operations, the picture may be distorted or the display of the remote control may turn off for a moment. This is not a malfunction.

- Performing ABB
- Turning on or off the Slow Shutter function

When switching the return video signal, the previously selected return signal may be displayed for a moment, or the picture may be distorted when the display switches. This is not a malfunction.

Specifications

General

Power requirements

When supplying power to the
CCU connector: DC 48 V

When supplying power to the
DC IN connector: 12 V (11 V
- 17 V)

Power consumption

DC 48 V: 75 W (max.)

DC 12 V: 70 W (max.)

Operating temperature

-10°C to +45°C (14°F to 113°F)

Operating humidity

20% to 90%

Storage temperature

-20°C to +60°C (-4°F to
+140°F)

Dimensions

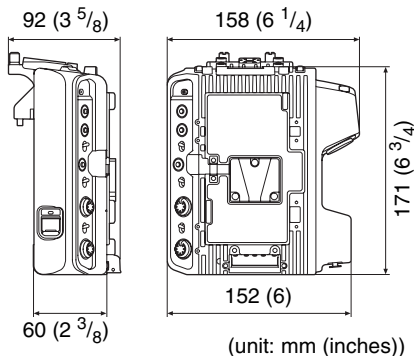

Mass Approx. 0.8 kg (1 lb 12 oz)

Connectors

Camera/Camcorder input/output connectors

Camera/Camcorder connector
50-pin, female

Output connectors

PROMPTER
BNC type, 75 Ω

Other connectors

CCU Optical composite connector
INTERCOM

XLR 5-pin, female

Camera/Camcorder power supply
5-pin, female

DC 12 V, maximum rated
current 5 A

DC IN XLR 4-pin, male, DC12 V
DC OUT

4-pin, female

DC 12 V, maximum rated
current 1.5 A

Supplied Accessories

Operating Instructions

Japanese/English (1)

CD-ROM (1)

Warranty booklet (1)

Cable clamp belt (1 set)

CA bracket (1)

Screws for CA bracket (2)

Accessory shoe kit (1)

Other peripheral devices

HXC-D70 HD Color Camera
 PMW-500/350/320 Solid-State Memory Camcorder
 HXCU-FB70 HD Camera Control Unit
 HXCE-FB70 Power Supply Unit
 DXF-51/C50WA Electronic Viewfinder
 CBK-VF01 HD Electronic Viewfinder
 HDVF-C550W HD Electronic Viewfinder
 AC-DN2B/DN10 AC Adaptor

Connectors for optical/electric composite cables:

- NEUTRIK® opticalCON DUO (to the “CAMERA” connector on CCU or POWER SUPPLY UNIT)
- NEUTRIK® opticalCON DUO (to the “CCU” connector on CAMERA ADAPTOR)

Caution on the optical/electric composite cable:

For connection between the camera control unit and camera adaptor, or between a power supply unit and camera adaptor, be sure to use an optical/electric signal composite cable with the connectors specified in this manual in order to comply with the limit for EMC regulations.

Design and specifications are subject to change without notice.

Note

Always verify that the unit is operating properly before use. SONY WILL NOT BE LIABLE FOR DAMAGES OF ANY KIND INCLUDING, BUT NOT LIMITED TO, COMPENSATION OR REIMBURSEMENT ON ACCOUNT OF THE LOSS OF PRESENT OR PROSPECTIVE PROFITS DUE TO FAILURE OF THIS UNIT, EITHER DURING THE WARRANTY PERIOD OR AFTER EXPIRATION OF THE WARRANTY, OR FOR ANY OTHER REASON WHATSOEVER.

Pin assignment

INTERCOM

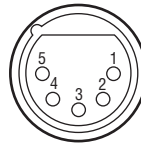

No.	Signal	IN/OUT	Specifications
1	Intercom MIC (Y)/ (GND) ¹⁾	IN	CARBON (-20 dBu, Unbalance) DYNAMIC (-60 dBu, Balance/ Unbalance) MANUAL
2	Intercom MIC (X)	IN	
3	GND	-	GND
4	Intercom Left	OUT	8 dBu (VR Max. 250 Ω Load)
5	Intercom Right	OUT	8 dBu (VR Max. 250 Ω Load)

(0 dBu=0.775 Vrms)

1) While set to UNBALANCE

DC IN

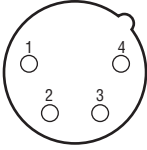

No.	Signal	IN/OUT	Specifications
1	EXT DC (C)	–	GND for DC (+)
2	NC		No connection
3	NC		No connection
4	EXT DC (H)	IN	+11 to +17 V dc

DC OUT



No.	Signal	IN/OUT	Specifications
1	UNREG GND	–	GND for UNREG OUT
2	NC		No connection
3	NC		No connection
4	UNREG OUT	OUT	+11 to +17 V dc. 1.5 A (max)

CCU

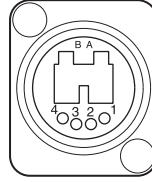

No.	Signal
A	Optical INPUT
B	Optical OUTPUT
1	DC IN (GND)
2	NC
3	NC
4	DC IN (+48V)

<http://www.sony.net/>

Sony Corporation