

**SONY®**

HD COLOR CAMERA

**HDC1700**

*Digital **HDVS***

OPERATION MANUAL  
1st Edition (Revised 4)

English

---

# Table of Contents

<b>Overview .....</b>	<b>3</b>
Features .....	3
System Configuration .....	5
<b>Locations and Functions of Parts .....</b>	<b>6</b>
Accessory Attachments .....	6
Controls and Connectors.....	6
<b>Preparations .....</b>	<b>12</b>
Attaching a Lens.....	12
Adjusting the Flange Focal Length.....	12
Attaching a Viewfinder.....	12
Attaching the Cable Clamp Belt (Supplied) .....	14
Adjusting the Shoulder Pad Position .....	15
Mounting the Camera to a Tripod.....	15
<b>Adjustments and Settings for Shooting .....</b>	<b>17</b>
Adjusting the Black Balance and White Balance.....	17
Setting the Electronic Shutter.....	19
Setting the Focus Assist Functions .....	19
Setting the Focus Position Meter Function.....	21
Setting the VF Dynamic Contract Function .....	22
<b>Setting the Camera Outputs.....</b>	<b>23</b>
<b>Viewfinder Screen Status Display .....</b>	<b>25</b>
<b>Menu Operations.....</b>	<b>26</b>
Starting Menu Operations .....	26
Selecting Pages .....	27
Setting the Menu Items .....	28
Editing the USER Menu .....	29
<b>Menu List .....</b>	<b>32</b>
Menu Tree .....	32
OPERATION Menu .....	38
PAINT Menu.....	48
MAINTENANCE Menu .....	53
FILE Menu.....	57
DIAGNOSIS Menu .....	60
<b>Appendix.....</b>	<b>61</b>
Precautions .....	61
Error Messages .....	61
<b>Using a USB Drive.....</b>	<b>62</b>
<b>Specifications.....</b>	<b>63</b>
Optional Accessories/Related Equipment .....	63
Dimensions.....	65

---

# Overview

The HDC1700 is 2/3-type high-definition portable video camera equipped with CCD for 2,200,000 pixels.

---

## Features

### High picture quality and high performance

HDC1700 features a 2/3-type wide progressive IT CCD for 2,200,000 pixels and a signal processing LSI, both newly developed to help achieve a high level of image quality. A 16-bit AD converter allows for optimal picture quality and enhanced black reproduction.

### Digital extender function

The central part of the viewfinder picture is digitally magnified to twice its size.

The digital extender function prevents the decrease in sensitivity (F-drop) that occurs when the lens extender function is used.

#### Note

This function reduces the resolution of images to one-half.

### Aberration correction function

This camera features ALAC 2.0 (Auto Lens Aberration Compensation).

When an achromatic lens is used, this function reduces chromatic aberration of magnification automatically.

*For details on achromatic lenses, contact a Sony sales representative or Sony service representative.*

### Standard optical digital transmission unit

Optical digital transmission of signals between the camera and HDCU1700 camera control unit is included.

## Various color-reproduction functions

### Adaptive-matrix function

This function accurately controls calculation factors for performing accurate color conversion when shooting. This makes precise color conversion possible even when shooting under conditions that would otherwise exceed the color conversion range of traditional matrix functions, such as under strong monochromatic blue light sources.

### Multimatrix color correction

In addition the standard 6-parameter matrix function, the camera has a multimatrix function that permits you to adjust the hue and chroma for color components in 16-axis directions independently. This is quite useful in color matching among multiple cameras.

### Knee saturation

Change of hue and decrease in chroma that occur in highlighted areas can be compensated.

This enables reproduction of natural skin tones under strong lighting.

### Low key saturation

Saturation in low-key zones can be compensated. Thus, compensation for color reproduction in all zones is enabled in combination with matrix color compensation and knee saturation functions.

### Selection of multiple gamma tables

Seven types of standard and 4 types of hyper gamma tables are provided with this camera. The hyper gamma values enable cinematic image creations with wide dynamic range, which are different from those achieved with conventional video gamma.

#### Note

When <CAM MODE> is set to 4K/HDR MODE, only VF images will be fixed to the ITU-R 709-equivalent gamma.

## Versatile detail control functions

### Skin-tone detail function/Natural skin detail function

Like HDC1500R/1400R, this function allows control (emphasis or suppression) of the detail level for just a certain hue or chroma area in the image, by creating a detail gate signal from color components of your specified hue, such as skin tones. The detail levels of three hues can be adjusted independently at the same time.

HDC1700 features the natural skin detail function, which allows for adjustment of the detail gate signal, allowing even more vivid distinction of areas like skin that you want to make smooth while selectively keeping areas like eyebrows that don't require smoothing.

### Detail boost-frequency control

The boost frequency can be adjusted from 20 to 30 MHz. This allows the thickness of the detail signal to be set appropriately for the subject, thus enabling high-definition image expression.

### H/V ratio control

The ratio between horizontal and vertical detail can be adjusted.

### White/black limiter

The white and black details can be limited independently.

### Focus assist functions

The VF detail function and focus assist indicator function facilitate focusing.

### VF detail

Various functions are provided for the VF detail signal, which can be added only on images on the viewfinder screen in order to facilitate focusing in various situations: Functions for coloring the VF detail signal, flickering the VF detail signal by adding modulation, thickening the VF detail signal, and changing the VF detail level according to the zoom position.

### **Focus assist indicator**

The focusing level indicator on the viewfinder screen provides a guide for focusing. The best focus setting can be easily determined by observing fluctuation of the level indicator as a guide.

### **VF dynamic contrast**

The VF contrast signal can be added only to images on the viewfinder screen, and facilitate focusing in situations with high brightness areas and low contrast levels.

### **Numerous viewfinder functions**

#### **Wide variety of viewfinder display options**

Along with items such as operation messages, a zebra pattern, a safety-zone marker, and a center marker, camera settings may also be displayed on the viewfinder screen. Furthermore, there are other indicators arranged above and below the viewfinder, such as a tally lamp, battery warning indicator, and an indicator to tell you that one or more settings are other than standard. This makes it simple to check the status of the camera.

#### **Menu-based setting operation function**

Selections and settings for viewfinder display items, a safety-zone marker or center marker, screen size marker, etc. can be made quickly and easily using setup menus displayed on the viewfinder screen or an external monitor.

### **User-friendly operation**

#### **Spirit level display function**

HDC1700 features a spirit level function, which enables you to display the amount of camera roll on the view finder screen and monitor. By checking the level of the camera, more stable shooting can be achieved.

#### **Unit-body with low center of gravity**

HDC1700, like the previous HDC1500 series, adopts a stylish appearance with low-slung design. When used in combination with the HDLA1500-series Large Lens Adaptor, it permits the viewfinder to be mounted at a low position, making the viewfinder position closer to the optical axis of the lens.

#### **Swing handle and VF slide mechanism**

A slight protrusion of the upper front part of the handle enables stable holding of the camera while you are shooting, by holding the front part of the handle. Furthermore, the movable range of a front-rear slide mechanism for the viewfinder attachment has been widened to provide the best balance for shooting with the camera on your shoulder. The swing handle mechanism allows for mounting and usage on the HDLA1500 series, making forward shifting with a large-scale viewfinder possible. This enables the same total longitudinal size as a standard studio-use camera, for operability equivalent to that of a standard studio-use camera.

### **Position-adjustable shoulder pad**

The position of the shoulder pad can be adjusted for stable shooting according to the build of the camera operator, the type of lens in use, or the shooting style. A low-repulsion shoulder pad (position fixed) is available as an option (Part No.: A-8286-346-A).

### **Function-assignable switches**

The function-assignable switches on the side panel can be assigned to your desired function, such as electronic color-temperature conversion. These switches can be synchronized with the assignable switches on viewfinder models such as HDVF-EL75, and can be used to operate the viewfinder functions such as MAGNIFICATION, etc. Also, two function-assignable switches are on the upper part of the handle, and can be used to set the viewfinder functions such as MAGNIFICATION, etc.

### **USB connector**

Connect a USB drive to the USB connector to record and read data. Setup menu settings can also be saved to and loaded from the USB drive.

### **Prevention of electrical shock**

When the power connection is unsafe, the power supply from the connected Camera Control Unit will be shut off.

### **Optional accessories**

You can add new functions and compatibility with other video formats by embedding the following optional accessories.

*For details on optional accessories, contact a Sony sales representative or Sony service representative.*

*For specifications or more detailed information on optional accessories, refer to the Operation Manual of each accessory.*

#### **HKC-DF20 Dual Optical Filter Unit**

Embedding the HKC-DF20 Dual Optical Filter Unit allows for a 2-filter (a CC filter and ND filter) configuration.

#### **HZC-UG444/UG444M/UG444W Support software for User Gamma Application**

Installing the HZC-UG444 User Gamma Application Software enables the camera to support CvpFileEditor™ and RGB4:4:4 outputs.

#### **HZC-PSF20/PSF20M/PSF20W Support software for PsF format**

Embedding HZC-PSF20 PsF format-compatible software makes creation of 1080/24PsF, 1080/23.98PsF, 1080/25PsF and 1080/29.97PsF formats possible.

#### **HZC-PRV20/PRV20M/PRV20W Support software for progressive format**

Embedding HZC-PRV20 progressive format-compatible software makes creation of 1080/50P and 1080/59.94P formats possible.

# System Configuration

## Note

Production of some of the peripherals and related devices shown in the figures has been discontinued. For advice on choosing devices, please contact your Sony dealer or a Sony sales representative.

## Connection example

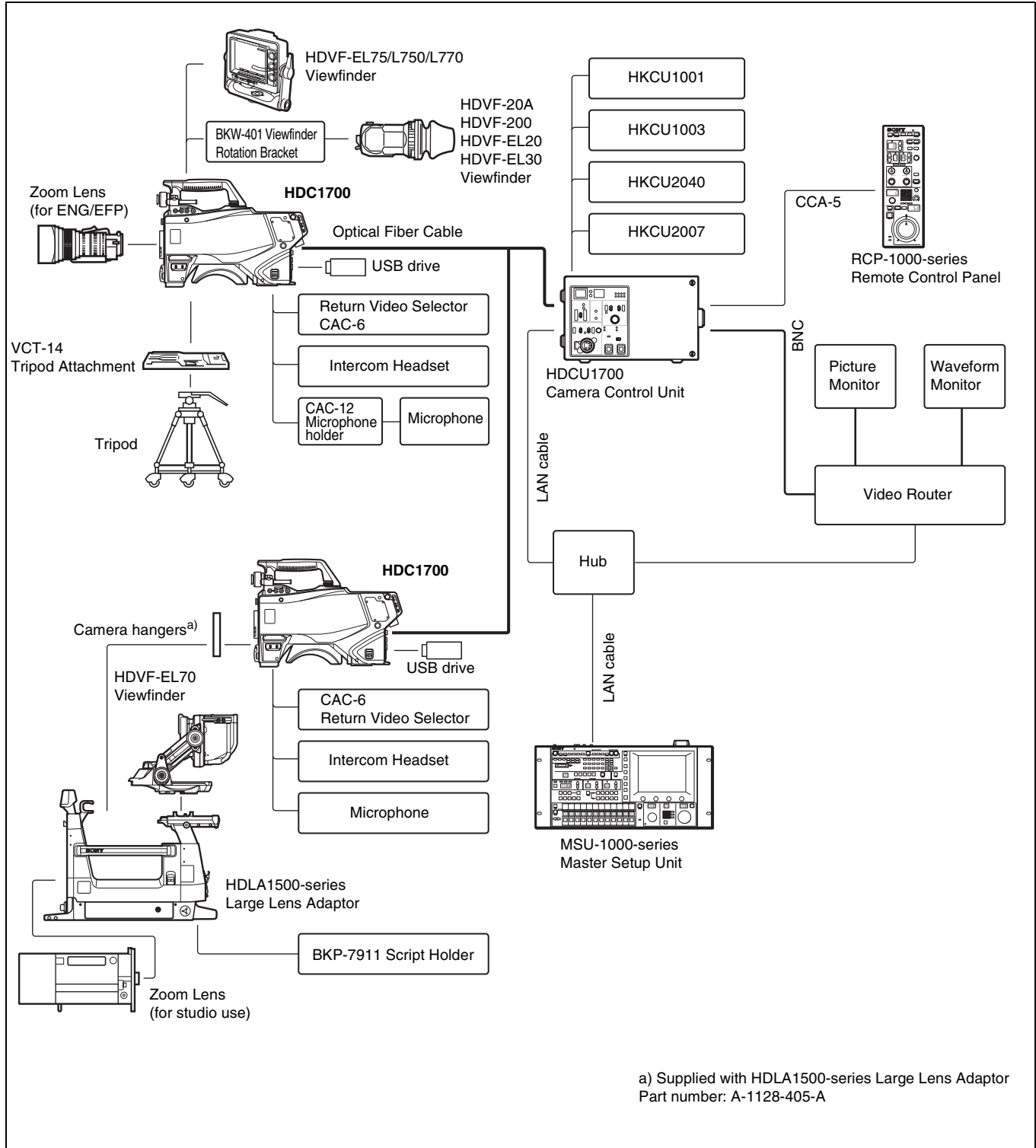

# Locations and Functions of Parts

## Accessory Attachments

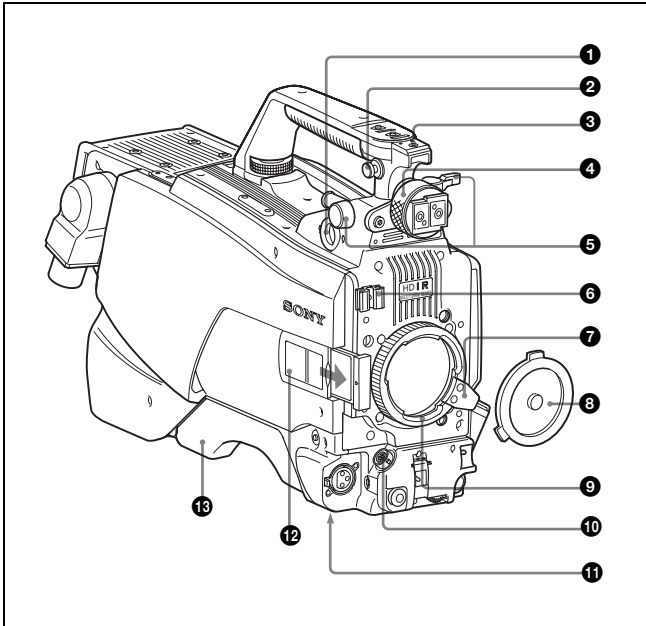

**1 VF (viewfinder) connector (20-pin)**  
Connect the cable of the viewfinder (not supplied).

**2 Shoulder strap fitting post**  
Attach one end of a shoulder strap (not supplied) to this fitting post, and the other end to the fitting post on the other side of the camera.

**3 Accessory shoe**  
To attach an accessory using a 1/4-inch screw.

**4 Viewfinder left-right positioning ring**  
Loosen this ring to adjust the viewfinder position towards the left or right.

**5 Viewfinder front-rear positioning lever and lock knob**  
Loosen the lever and knob to adjust the viewfinder position towards the front or rear.

*For details on adjusting the viewfinder position, see "Attaching a Viewfinder" on page 12.*

**6 Lens cable clamp**  
To secure the cable of the lens (not supplied).

**7 Lens fixing lever**  
To secure the lens in the lens mount.

**8 Lens mount cap**  
The cover can be removed by moving the lens fixing lever upwards. Always keep the lens mount covered with this cap when a lens is not attached.

**9 Lens mount**  
To attach a lens.

**10 LENS connector (12-pin)**  
Connect the lens cable. The camera can control the lens functions through this cable.

**11 Tripod mount**  
Attach the VCT-14 Tripod Attachment when mounting the camera on a tripod.

**12 Camera number**  
Insert the supplied camera number label. You can display the camera number.

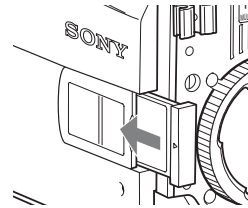

**13 Shoulder pad**  
You can adjust the position so that you can get the best balance for shooting with the camera on your shoulder.

*For details, see "Adjusting the Shoulder Pad Position" on page 15.*

## Controls and Connectors

### Front right

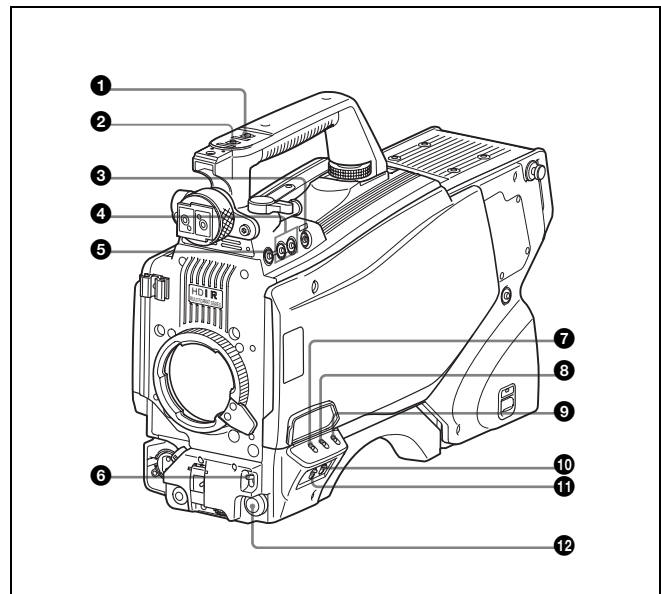

**1 INCOM (intercom 1) button**  
The intercom 1 microphone is turned ON while this button is held pressed.  
You can also assign other functions to this button, using the menu displayed on the viewfinder screen.

## 2 RET 1 (return video 1) button

The return video 1 signal from the camera control unit is monitored on the viewfinder screen while this button is pressed. Its function is the same as the RET 1 button on the side (page 8) and that on the operation panel on the rear of the camera (page 9 or 10).

You can also assign other functions to this button, using the menu displayed on the viewfinder screen.

## 3 Assignable switch

You can assign a function using the menu displayed on the viewfinder screen.

## 4 Filter select buttons

You can switch the built-in optical filters (clear, 1/4ND, 1/16ND, 1/64ND, cross) by pressing either of these buttons while holding the FILTER LOCAL button depressed.

## 5 FILTER LOCAL button

While holding this button depressed, press either of the filter select buttons to select the built-in optical filters.

## 6 AUTO W/B BAL (white and black balance automatic adjustment) switch

To automatically adjust white and black balance when the camera is used in standalone status without connecting to the camera control unit.

**WHT:** Automatically adjust white balance.

**BLK:** Automatically adjust black balance.

## 7 GAIN switch

To select the gain of the video amplifier based on lighting conditions when the camera is used in standalone status without connecting a camera control unit.

When shipped from the factory, the values set are L = 0 dB, M = 6 dB, and H = 12 dB.

## 8 OUTPUT (output signal selection)/AUTO KNEE switch

To select the signal (color bar signal or camera's video signal) to be used as output to a VTR, the viewfinder or a video monitor when the camera is used in standalone status without connecting a camera control unit.

When the camera's video signal is being used as output, the auto knee function may be used.

The relationship between the switch setting and the output signal and auto knee function is shown in the table below.

OUTPUT	AUTO KNEE	Function
BARS	OFF	Output is a color bar signal.
CAM	OFF	Output is the camera's video signal. The auto knee circuit is disabled.
CAM	ON	Output is the camera's video signal. The auto knee circuit is enabled.

## 9 WHITE BAL (white balance memory selection) switch

To select the white balance adjustment method or the memory used to store the adjusted value when the camera is used in standalone status without connecting a camera control unit.

**PRST (preset):** White balance is adjusted to a preset value corresponding to a color temperature of 3200K.

**A or B:** Selects memory A or B.

## 10 DISPLAY switch

The functions of the DISPLAY switch are as follows:

**DISPLAY:** Characters and messages showing the camera settings and operating status may be displayed on the viewfinder screen.

**OFF:** Status messages will not appear on the viewfinder screen.

**MENU:** Menus for camera settings will be displayed on the viewfinder screen.

## 11 STATUS/CANCEL switch

**STATUS:** When no menu is displayed on the viewfinder screen, the status information of this camera is displayed.

**CANCEL:** When a menu is displayed on the viewfinder screen, you can cancel any changed settings or return the display to the previous menu.

## 12 MENU SEL (menu select) knob/ENTER button (rotary encoder)

To select settings from menus displayed on the viewfinder screen (by rotating the knob) and to confirm settings (by pushing the button).

You can change the ECS frequency by pushing the ENTER button when no menu is displayed on the viewfinder screen.

Make sure that the camera is used in standalone status without connecting a camera control unit, and the shutter mode is set to ECS. When the camera is used in standalone status and the shutter mode is set to other than ECS, the VF DETAIL function can be adjusted.

### Note

When a camera control unit or a remote control device, such as an MSU or RCP-series Remote Control Panel, is connected, the functions of 6 to 9 are controlled from the external control device and the controls on the camera are disabled.

## Front left

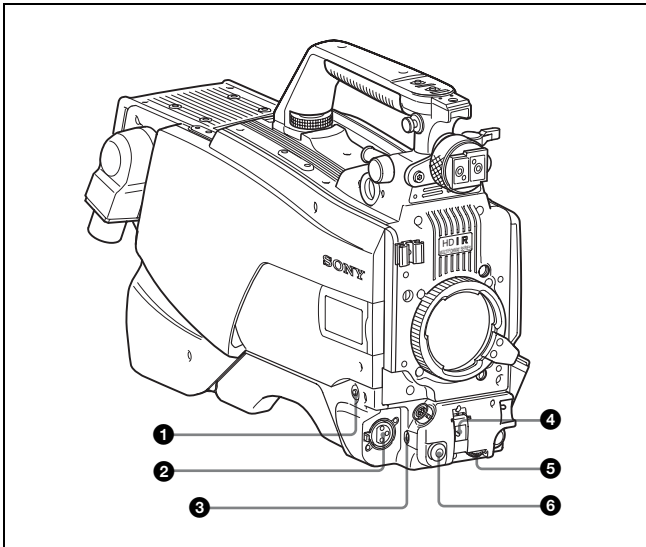

### 1 RET 1 (return video 1) button

The return video 1 signal from the camera control unit is monitored on the viewfinder screen while this button is pressed. It function the same as the RET 1 buttons on the handle (page 7) and that on the operation panel on the rear of the camera (page 9 or 10).

You can also assign other functions to this button, using the menu displayed on the viewfinder screen.

### 2 MIC 1 IN (microphone 1 input) connector (XLR 3-pin)

Connect a microphone.

This connector and the AUDIO IN CH-1 connector (page 11) on the operation panel on the rear of the camera are alternately activated with the CH1 audio input select switch (page 11).

### 3 MIC (microphone) power switch

**+48V:** To supply a power of +48 V to the connected microphone.

**OFF:** Not to supply a power to the connected microphone.

### 4 SHUTTER switch

For setting the electronic shutter functions when the camera is used in standalone status without connecting a camera control unit.

**OFF:** The electronic shutter does not function.

**ON:** The electronic shutter is activated.

**SEL:** The shutter speed and shutter mode change each time the switch is set to this position.

For details, see "Setting the Electronic Shutter" on page 19.

### 5 INTERCOM LEVEL control

To adjust the intercom/earphone volume level.

The intercom level adjustment is enabled when the INTERCOM 1 and 2 LEVEL/MIC switches (on the SY-type operation panel, page 9) or the LEVEL switch (on the European-type operation panel, page 10) on the rear of the camera are set to "FRONT."

### 6 RET 2 (return video 2) button

When this button is pressed, the picture on the viewfinder screen changes to the return video signal selected with the RET 2 select switch (page 9 or 10) on the operation panel on the rear of the camera.

You can also assign other functions to this button, using the menu displayed on the viewfinder screen.

## Rear

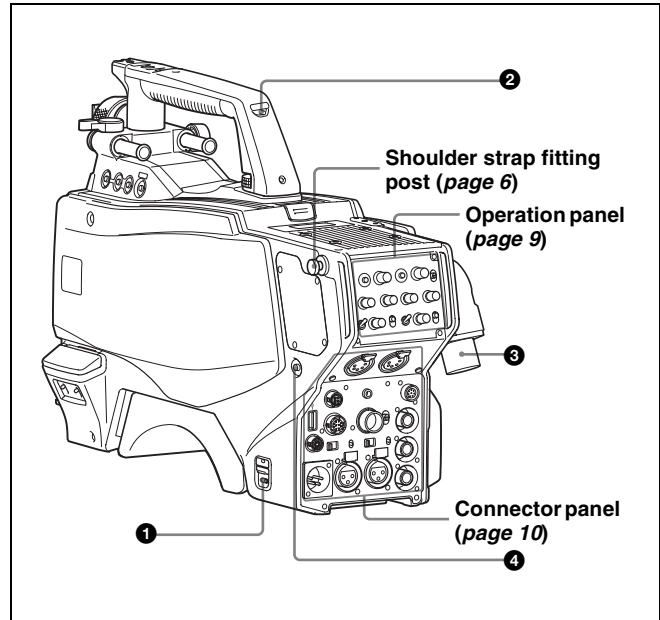

### 1 CAMERA POWER switch

**CCU:** Power is supplied from the camera control unit.

**EXT:** Power is supplied through the DC IN connector.

### 2 Tally lamp and switch

**ON:** The tally lamp lights when a tally signal is input to the connected camera control unit or a call signal is generated in response to pressing of a CALL button.

**OFF:** The tally lamp is prevented from lighting.

### 3 CCU (Camera Control Unit) connector (optical/electrical multi-connector)

Connect a camera control unit using an optical electro-composite cable.

### 4 CALL button

When this button is pressed, the red tally lamp of the RCP-1000-series Remote Control Panel or the MSU-1000-series Master Setup Unit will light. Use to call the operator of the RCP or MSU.



## Operation panel

**SY type:** For JN/SY (USA, Canada, East Asia and other countries) models (for NTSC areas)

For details on the differences among models, see "Overview" on page 3.

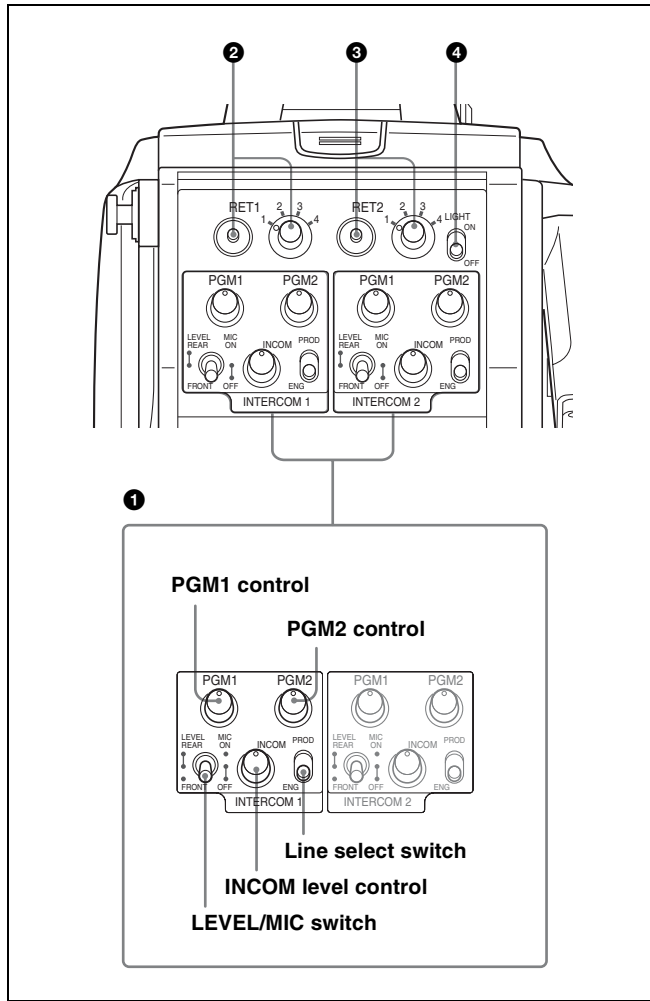

**1 INTERCOM1 and INTERCOM2 controls and switches**  
There are PGM1 and 2 controls incorporated with a line select switch, a LEVEL/MIC switch, and INCOM level control each for intercom line 1 and 2.

**PGM1 (program 1) control**  
Adjust the audio listening level of program 1.

**PGM2 (program 2) control**  
Adjust the audio listening level of program 2.

### LEVEL/MIC switch

**REAR/ON:** The intercom headset microphone is turned on.  
The intercom audio listening level is adjusted with the INCOM level control.

**REAR/OFF:** The intercom headset microphone is turned off.  
The intercom audio listening level is adjusted with the INCOM level control.

**FRONT/OFF:** The intercom headset microphone is turned off.  
The intercom audio listening level is adjusted with the INCOM level control and the INTERCOM LEVEL control on the front of the camera (page 8).

**INCOM level control**  
Adjust the intercom audio listening level.

**Line select switch**  
Select the intercom line.

**PROD:** Producer line  
**ENG:** Engineer line

**2 RET 1 (return video 1) button and select switch**  
Press the button to display the return video signal selected with the switch on the viewfinder screen.

**3 RET 2 (return video 2) button and select switch**  
If you use an additional return video system in addition to return video 1, press the button to display the return video signal selected with the switch on the viewfinder screen.

### Note

The RET 1 button has priority over the RET 2 button if both buttons are pressed.  
If RET 1 and RET 2 buttons are pressed at the same time, the two buttons function as the RET 3 button when setting <RETURN> 12 of the OPERATION menu.

**4 LIGHT switch**  
Set to ON to illuminate the operation panel.

**European type:** For CE (Europe) and E (China and South Asia) models (for PAL areas)

For details on the differences among models, see "Overview" on page 3.

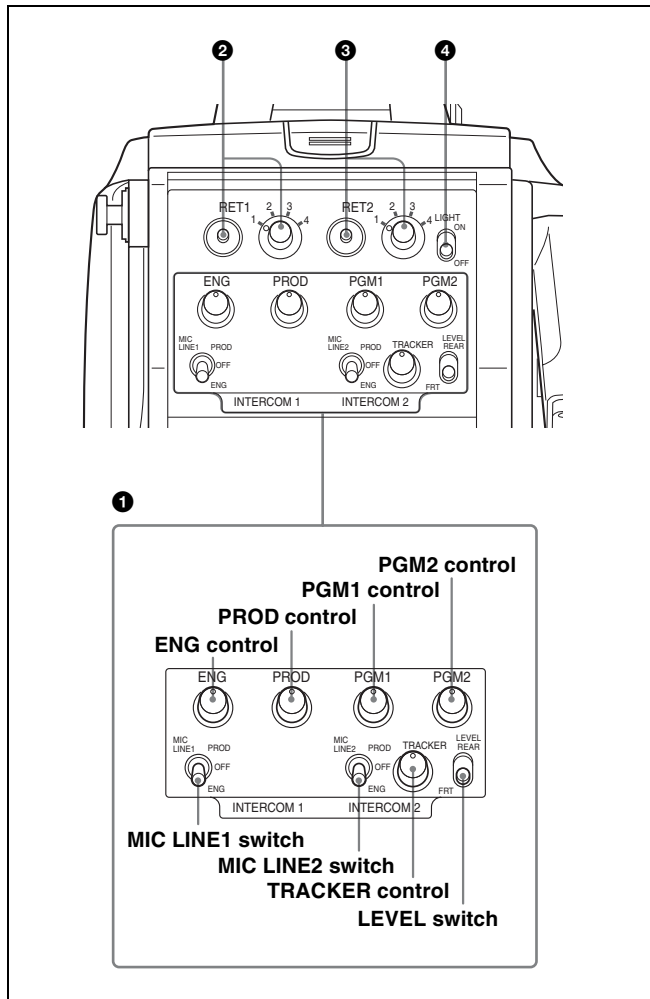

**1 INTERCOM1 and INTERCOM2 controls and switches**  
The reception level controls are common to intercom 1 and intercom 2. The talk lines can be set independently for intercom 1 and intercom 2.

**ENG (engineer line) control:**

Adjust the intercom audio listening level of the engineer line.

**PROD (producer line) control**

Adjust the intercom audio listening level of the producer line.

**PGM1 (program 1) control**

Adjust the audio listening level of program 1.

**PGM2 (program 2) control**

Adjust the audio listening level of program 2.

**TRACKER control**

Adjust the intercom audio listening level at the TRACKER connector (page 11) on the connector panel when using the connector for intercom.

**MIC LINE1 (intercom microphone line 1) switch**

Select the talk line for intercom 1.

**PROD:** To talk over the producer line

**OFF:** To turn off the headset microphone for intercom line 1.

**ENG:** To talk over the engineer line

**MIC LINE2 (intercom microphone line 2) switch**

Select the talk line for intercom 2.

**PROD:** To talk over the producer line

**OFF:** To turn off the headset microphone for intercom line 2.

**ENG:** To talk over the engineer line

**LEVEL switch**

**REAR:** The intercom audio listening level is adjusted with the controls on this panel.

**FRT:** The intercom audio listening level is adjusted with the INTERCOM LEVEL control on the front of the camera.

**2 RET 1 (return video 1) button and select switch**

The return video signal selected with the switch is displayed on the viewfinder screen while the button is pressed.

**3 RET 2 (return video 2) button and select switch**

When other return video systems are used in addition to return video 1, you can monitor the signal selected with the switch on the viewfinder screen while pressing the button.

**Note**

The RET 1 button has priority over the RET 2 button if both buttons are pressed.

If RET 1 and RET 2 buttons are pressed at the same time, the two buttons function as the RET 3 button when setting <RETURN> 12 of the OPERATION menu.

**4 LIGHT switch**

Set to ON to illuminate the operation panel.

**Connector panel**

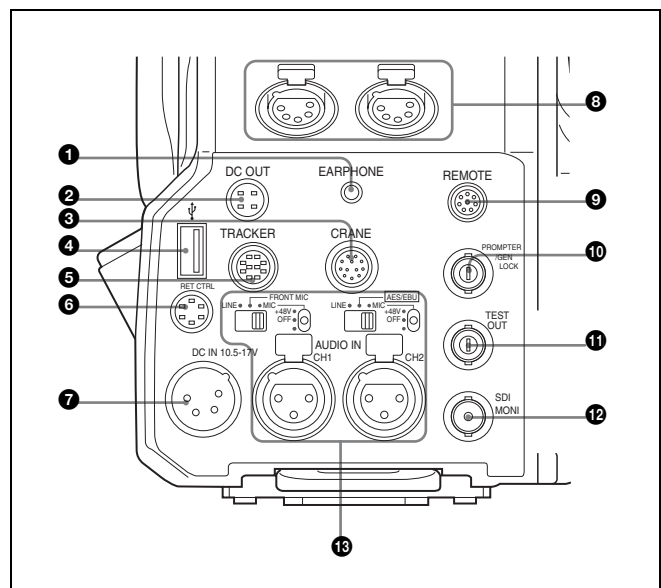

**1 EARPHONE jack (stereo minijack)**

For connecting an earphone or headset to hear the intercom audio.

**2 DC OUT (DC power supply output) connector (4-pin)**

To supply power to devices such as a wireless receiver (optional) (max. 0.5 A).

### 3 CRANE connector (12-pin)

For external interface, such as viewfinder (and external data with HDC1700).

### 4 USB connector (for connecting a USB drive)

Connect a USB drive to save or load the settings data file.

For details, see "Using a USB Drive" (page 62).

### 5 TRACKER connector (10-pin)

For external interface, such as intercom and tally.

### 6 RET CTRL (return control) connector (6-pin)

For connection to a CAC-6 Return Video Selector.

### 7 DC IN (DC power supply input) connector (XLR 4-pin)

Used for connection to the AC-DN10 AC Adaptor to supply power to the camera.

### 8 INTERCOM1 and 2 (intercom 1 and 2) connectors (XLR 5-pin)

Used for input and output of intercom audio signals if an XLR 5-pin headset is connected.

The INTERCOM 1 connector can be used for communication over the engineer line even when the power is off, as long as the power LED is lit in red.

### 9 REMOTE connector (8-pin)

For connection to an RCP-1000/1500-series Remote Control Panel, or MSU-1000/1500 Master Setup Unit.

#### Note

When the camera is connected to a CCU, do not connect any remote control device, such as RCP and MSU, to this connector.

### 10 PROMPTER/GENLOCK (prompter 1 signal output/ external gen-lock signal input) connector (BNC-type)

The PROMPTER function is available only when a camera control unit is connected.

The GENLOCK IN function and RET IN function are available when a camera control unit is not connected.

**GENLOCK IN:** For input of an external gen-lock signal (VBS or 3-level sync) during stand-alone operation.

**RET IN:** For input of the return video signal during stand-alone operation.

The connector accepts analog HD signals only. SDI signals are not acceptable. Supply a signal of 1080i (720P is not acceptable).

The signal supplied to this connector cannot be fed as RET OUT from the TEST OUT or SDI OUT connector. This is displayed in the viewfinder regardless of which RET is selected. CHARACTER will not be overlapped for the displayed RET 3 signal.

**PROMPTER:** For output of the prompter 1 signal (valid only when a camera control unit is connected). When a camera control unit having two prompter inputs is connected, the signal of input 1 is output from this connector.

### 11 TEST OUT connector (BNC-type)

To output the analog signal.

This also supplies the VBS signal, an HD signal nearly equal to the signal output from the VF connector, an HD-SYNC

signal, or an SD-SYNC signal depending on which of these you have selected on the menu.

For details on the output signals, see "Setting the Camera Outputs" (page 23).

### 12 SDI-MONI (serial digital interface) connector (BNC-type)

For HD-SDI or SD-SDI signal output.

For details on the output signals, see "Setting the Camera Outputs" (page 23).

### 13 AUDIO IN CH1 and CH2 connectors (XLR 3-pin) and switches

Connect audio signals. An input select switch and microphone power switch are provided for each channel.

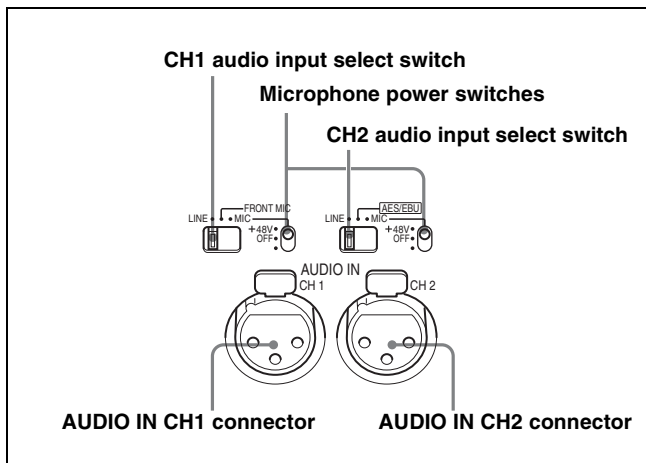

#### CH1 audio input select switch

Set to the appropriate position according to the equipment connected to the AUDIO IN CH1 connector.

**LINE:** When a line-level (0 dBu) signal source is connected

**FRONT MIC:** When using the microphone connected to the MIC 1 IN connector

**MIC:** When an external microphone is connected

#### CH2 audio input select switch

Set to the appropriate position according to the equipment connected to the AUDIO IN CH2 connector.

**LINE:** When a line-level (0 dBu) signal source is connected

**AES/EBU:** When a digital audio signal is connected (The signal must be in synchronization with the camera output).

**MIC:** When an external microphone is connected

#### Microphone power switches

When a microphone is connected to the corresponding AUDIO IN connector, set whether or not to supply a power to the microphone.

**+48V:** To supply a power of +48 V

**OFF:** Not to supply a power

(No function has been assigned to the lowermost position. No power is supplied to the microphone.)

#### Note

To supply +12 V power, contact a Sony sales representative or Sony service representative.

# Preparations

## Attaching a Lens

For information on handling lenses, refer to the lens' operation manual.

### Attaching procedure

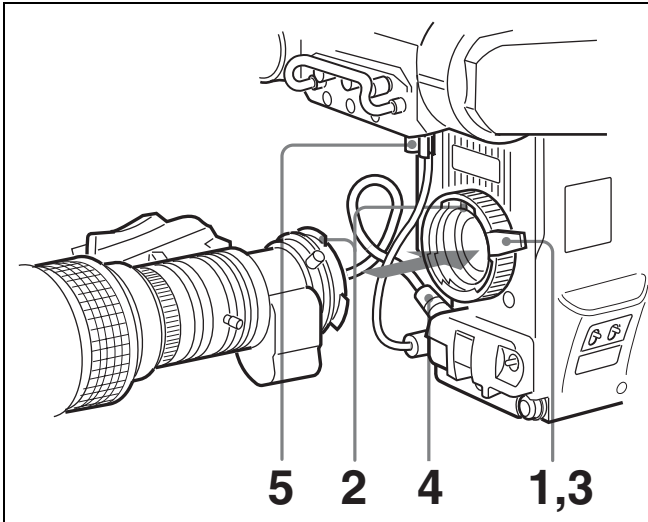

- 1 Push the lens fixing lever upwards and remove the lens mount cap from the lens mount.
- 2 Align the lens' alignment pin with the notch in the upper part of the lens mount and insert the lens into the mount.
- 3 While supporting the lens, push the lens fixing lever downwards to secure the lens.
- 4 Connect the lens cable to the LENS connector.
- 5 Secure the lens cable with the cable clamp.

## Adjusting the Flange Focal Length

Adjustment of the flange focal length (the distance between the lens mount attachment plane and the imaging plane) is necessary in the following situations:

- The first time a lens is attached
- When changing lenses
- If the focus is not sharp at both telephoto and wide angle when zooming

The flange focal length can be more precisely adjusted by using the focus assist indicators.

See "Displaying the focus assist indicators" on page 20 for the focus assist indicators.

### Note

The various parts of the lens used in adjusting the flange focal length are in different positions on different lenses. Refer to the operation manual for the particular lens.

### Adjusting procedure

- 1 Set the iris control to manual, and open the iris fully.
- 2 Place a flange focal length adjustment chart approximately 3 meters from the camera and adjust the lighting to get an appropriate video output level.
- 3 Loosen the Ff (flange focal length) ring lock screw.
- 4 With either manual or power zoom, set the zoom ring to telephoto.
- 5 Aim at the flange focal length adjustment chart and turn the focus ring to focus the image.

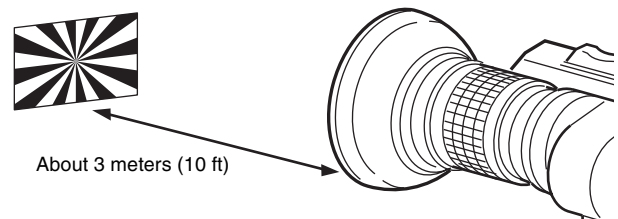

- 6 Set the zoom ring to wide angle.
- 7 Turn the Ff ring to bring the chart into focus. Take care not to move the distance ring.
- 8 Repeat steps 4 through 7 until the image is in focus at both telephoto and wide angle.
- 9 Tighten the Ff ring lock screw.

## Attaching a Viewfinder

### Caution

When the viewfinder is attached, do not leave the camera with the eyepiece facing the sun. Direct sunlight can enter through the eyepiece, be focused in the viewfinder and cause fire.

### Attaching a viewfinder

The instructions are made using the HDVF-20A/200 viewfinder as an example.

For details on the viewfinder, refer to the instruction manual of the viewfinder.

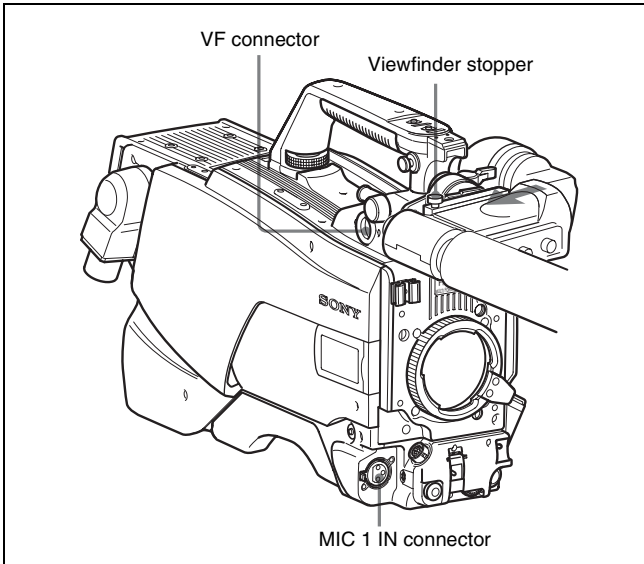

- 1** Slide the viewfinder in the direction of the arrow. The viewfinder stopper automatically pops down.
- 2** Loosen the viewfinder left-right positioning ring, slide the viewfinder side to side to the most convenient position and tighten the ring. (See “To adjust the position to the left or right” below.)
- 3** Connect the viewfinder cable to the VF connector of the camera.
- 4** Connect the microphone cable to the MIC 1 IN connector of the camera.

### Adjusting the viewfinder position

The viewfinder position may be adjusted towards the front and rear and to the left and right to make it easy to see into it.

### To adjust the position to the left or right

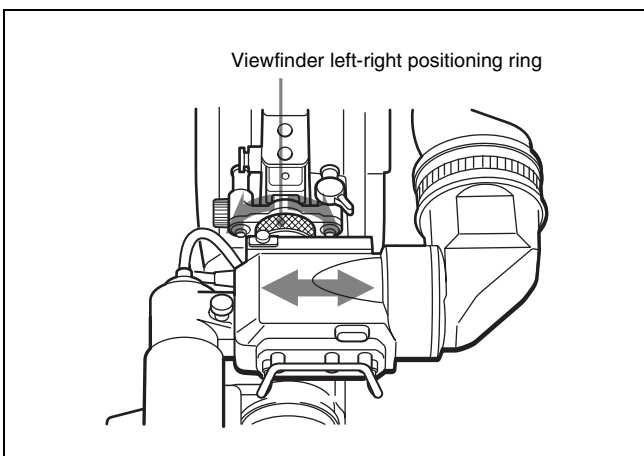

- 1** Loosen the viewfinder left-right positioning ring.

- 2** Slide the viewfinder left or right to move it into a good viewing position.
- 3** Tighten the viewfinder left-right positioning ring.

### To adjust the position forward or backward

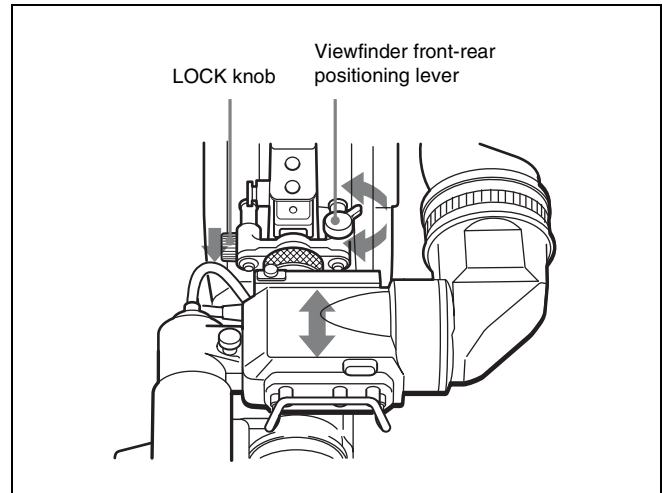

- 1** Loosen the viewfinder front-rear positioning lever and LOCK knob.
- 2** Slide the viewfinder towards the front or rear of the camera to move it into a good viewing position.
- 3** Tighten the viewfinder front-rear positioning lever and LOCK knob.

### Detaching the viewfinder

Loosen the viewfinder left-right positioning ring, pull the viewfinder stopper, then pull out the viewfinder by sliding it in the direction opposite to that when attached.

### Keeping the viewfinder from hitting your leg (using BKW-401)

To keep the viewfinder from bumping your leg when carrying the camera, install the BKW-401 Viewfinder Rotation Bracket (optional) and rotate the viewfinder upwards.

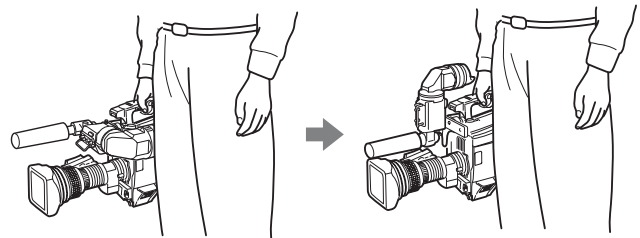

### Note

Lock the viewfinder in a slightly forward position before rotating it upwards. If the viewfinder is in its rearmost position, the arm of the viewfinder rotation bracket will strike the grip.

## Attaching procedure of the BKW-401

- 1 Turn the arm of the rotation mechanism assembly of the BKW-401 in the direction of the arrow in the following illustration.

Next, using a hexagonal wrench 3 mm across flats, remove the bolts (M4 × 8) together with the washers, to separate the rotation mechanism assembly from the viewfinder front-back positioning mechanism assembly.

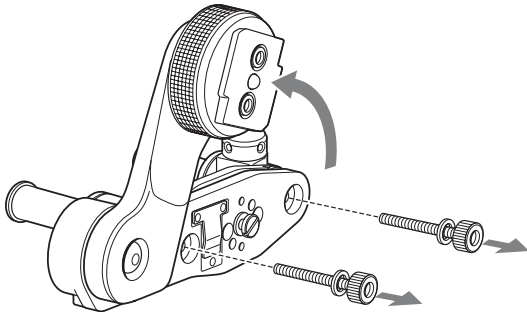

- 2 In the same manner as step 1, remove the viewfinder shoe of the camera from the front-rear positioning mechanism.

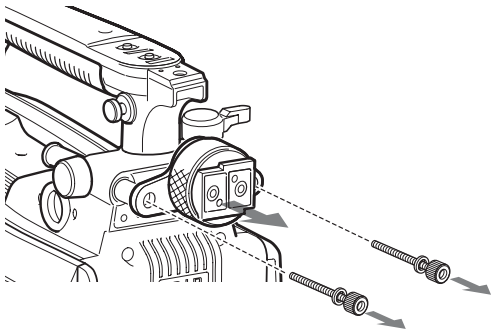

- 3 Using the two bolts (M4 × 8) and the washers removed from the camera in step 2, attach the rotation mechanism assembly of the BKW-401 to the camera.

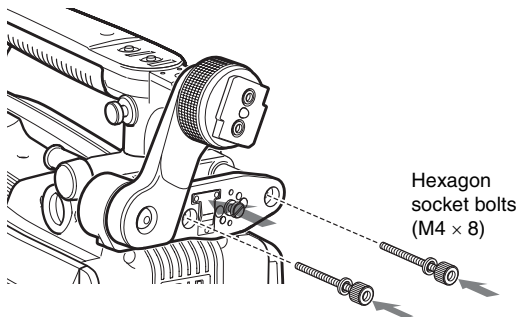

- 4 Adjust the front-rear position so that the camera handle does not interfere when you rotate the BKW-401 arm upwards.

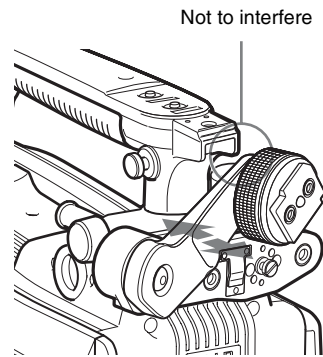

## Attaching the Cable Clamp Belt (Supplied)

You can secure the camera cable to the camera by attaching the supplied cable clamp belt.

- 1 Insert the belt bracket into hole (A) or (B) of the cable clamp belt.

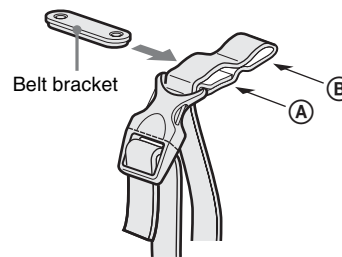

- 2 Remove two +B3×5 screws and a blind screw shown in the figure below from the camera.

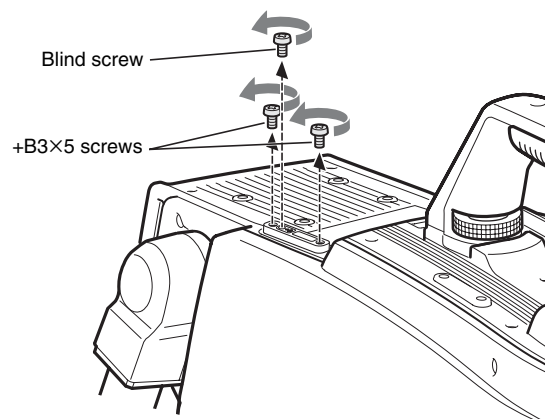

- 3** Secure the cable clamp belt to the camera, using the two supplied +B3×8 screws.

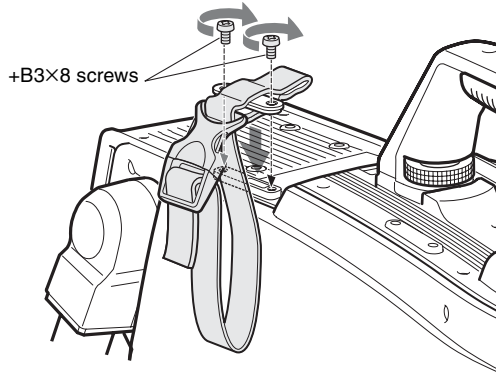

- 4** ① Release the buckle, ② bundle the cable with the belt, ③ then lock the buckle again.

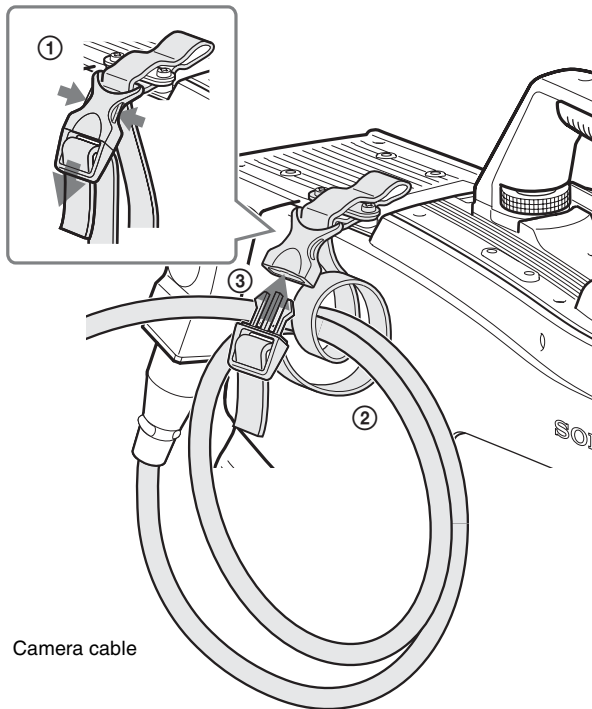

- 5** Adjust the length by pulling down the end of the belt.

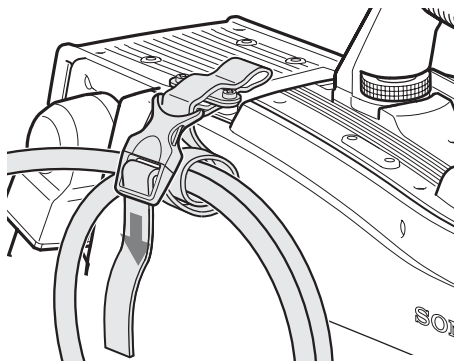

## Adjusting the Shoulder Pad Position

You can shift the shoulder pad from its center position (factory setting) backward by up to 10 mm (3/8 inch) or forward by up to 25 mm (1 inch). This adjustment helps you get the best balance for shooting with the camera on your shoulder.

### Adjusting procedure

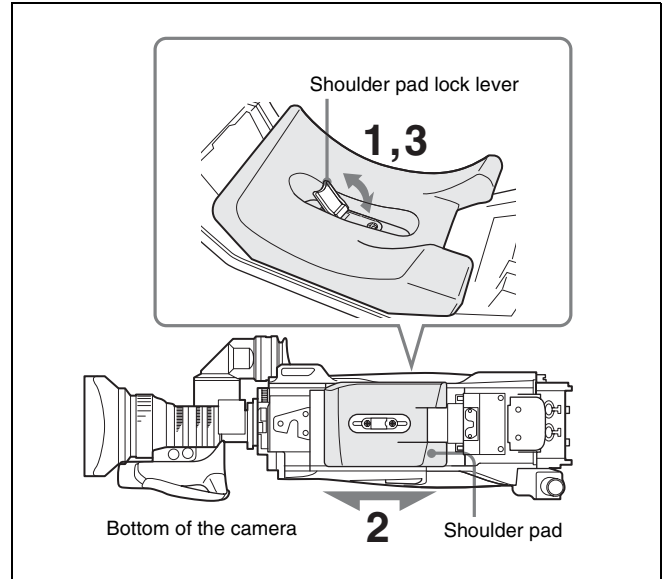

- 1** Raise the lever in the center of the shoulder pad to unlock the shoulder pad.
- 2** Slide the shoulder pad backward or forward until it is in the most convenient position.
- 3** Move the lever down to lock the shoulder pad in the selected position.

## Mounting the Camera to a Tripod

Mount the camera to a tripod using a VCT-14 Tripod Attachment.

### Caution

- Select an appropriate hole from among those at the bottom of the tripod attachment considering the balance of the weight of the camera and the tripod attachment. If an inappropriate hole is selected, the camera may fall over.
- Check that the size of the selected hole matches that of the screw of the tripod. If they do not match, the tripod attachment cannot be attached to the tripod securely.

## Mounting procedure

- 1 Attach the tripod attachment to the tripod and secure it with the screw.**

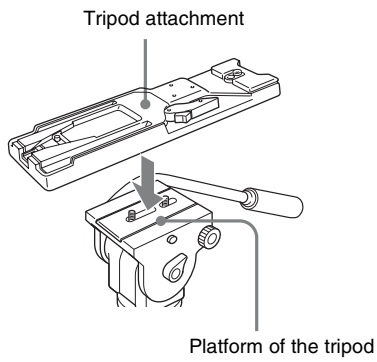

- 2 Place the camera on the tripod attachment, and slide forward it along the groove of the tripod attachment until it clicks.**

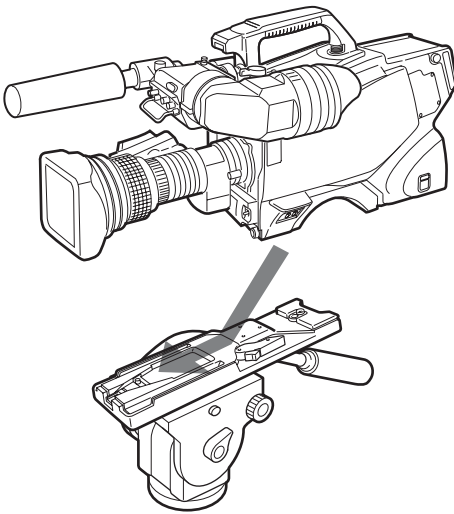

- 3 Make sure that the camera is securely attached by moving it back and forth.**

### To remove the camera from the tripod attachment

Hold down the red button and pull the lever in the direction of the arrow.

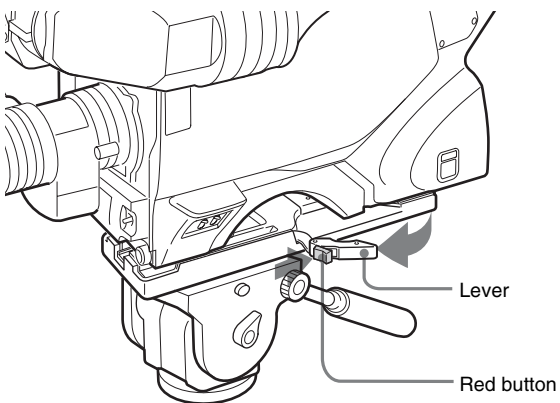

### If the pin of the tripod attachment does not return to its original position

After removing the camera, if the pin of the tripod attachment does not return to its original position, hold down the red button and move the lever in the direction of the arrow to return the pin to its original position. It is not possible to mount a camera with the pin not seated.

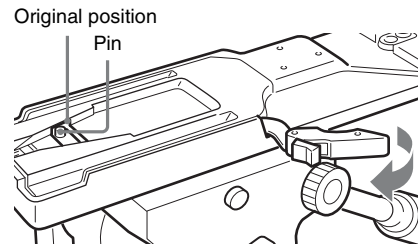



# Adjustments and Settings for Shooting

## Adjusting the Black Balance and White Balance

In order to maintain high picture quality, it is necessary to set the black balance and white balance appropriately for the conditions.

### Note

When a camera control unit or a remote control device—such as the MSU or RCP series—is connected, control is performed from the RCP/MSU, and the switches on the camera are disabled.

### Black balance adjustment

The black balance needs adjustment in situations like the following:

- The first time the camera is used
  - When the camera is used after a long period of disuse
  - When the surrounding temperature changes greatly
  - When the gain value is changed using the setup menus
- Normally, there is no need to adjust the black balance every time the camera is turned on.

### White balance adjustment

Always readjust the white balance when lighting conditions change.

### About the viewfinder screen

After the process of adjusting the black balance or white balance begins, messages about the progress and results of the adjustment will be displayed on the viewfinder screen.

### Note

Adjusted values set through automatic adjustment, and other settings, are stored in the camera's memory and preserved even when the camera power is turned off.

### Adjusting the black balance

Push the AUTO W/B BAL switch toward BLK (downward).

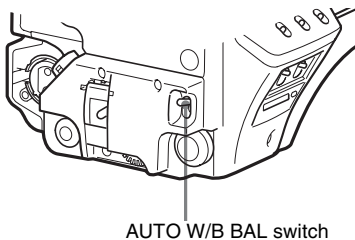

Automatic adjustment of black balance begins.

In automatic adjustment of black balance, both the black set and black balance are adjusted.

During adjustment, a message like the one in the figure below will be displayed on the viewfinder screen.

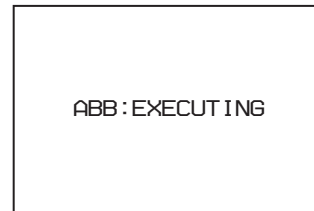

When the adjustment process is completed, the message "ABB: OK" will be displayed. The adjusted value is automatically stored in memory.

### Notes

- During black balance adjustment, the iris will be automatically closed.
- During black balance adjustment, the gain switching circuit will work automatically, and the viewfinder screen will flicker several times. This is not a malfunction.

### When automatic black balance adjustment fails

If the automatic black balance adjustment process does not end successfully, the error message "ABB: NG" will be displayed on the viewfinder screen for approximately three seconds.

If this error message is displayed, try black balance adjustment again.

If the error message continues to be displayed after several attempts, the camera requires internal inspection.

### About black balance memory

The black balance values stored in memory will be preserved even when the camera power is turned off.

### Adjusting the white balance

- 1 Set the WHITE BAL switch to A or B.

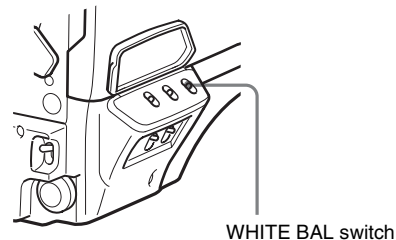

**2 Select the filter setting according to the lighting conditions.**

Press the filter select UP or DOWN button while holding the FILTER LOCAL button depressed.

Each press of the UP or DOWN button switches the available optical filters in sequence.

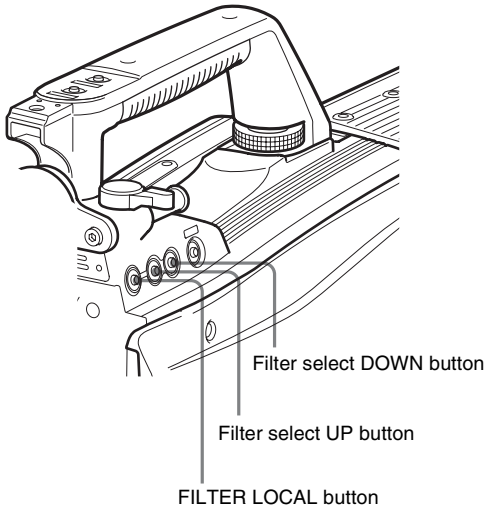

Optical filter	
1	clear
2	1/4 ND
3	1/16 ND
4	1/64 ND
5	cross

**3 Place a white pattern in the same lighting conditions as the subject, and zoom in on it so that a white area is obtained in the screen to satisfy the positional and quantitative requirements illustrated below.**

A white object (white cloth, a white wall, etc.) near the subject may be used in place of a white pattern.

A rectangle centered in the screen. The length of the sides must be at least 70% of the height and width of the screen.

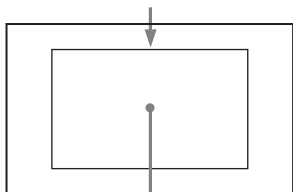

Within this rectangle, there must be an area of white greater than 10% of the entire screen.

**Note**

Be careful not to have any spots of high illumination in the rectangle.

**4 Adjust the lens iris opening.**

**With a manually adjusted lens:** Set the opening to an appropriate value.

**With a lens which has automatic iris control:** Set the lens' automatic/manual iris control switch to automatic.

**5 Push the AUTO W/B BAL switch to WHT and release the switch.**

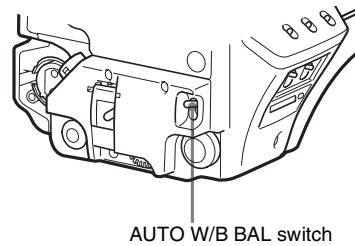

The switch will return to the center position, and adjustment will be performed.

During adjustment, the message "AWB: EXECUTING" will be displayed on the viewfinder screen.

A message like the one in the figure below will be displayed, and the adjustment process will complete. The adjusted value will be automatically stored in the memory (A or B) selected in step 1.



**Note**

When using a zoom lens with automatic iris control capability, hunting<sup>1)</sup> may occur. Adjust the lens' iris gain control (labeled IG, IS, S, etc.).

<sup>1)</sup> Hunting: The automatic iris responds over and over, and the image repeatedly darkens and lightens.

For more information, refer to the lens' operation manual.

**When automatic white balance adjustment fails**

If the white balance adjustment process does not end successfully, the error message "AWB: NG" will be displayed on the viewfinder screen for approximately three seconds. If this error message is displayed, try white balance adjustment again.

If the error message continues to be displayed after several attempts, the camera requires internal inspection.

**When there is no time to adjust the white balance**

Set the WHITE BAL switch to PRST. The white balance will be set automatically according to the filter settings.

## About white balance memory

The white balance values stored in memory will be preserved even when the camera power is turned off.

There are two white balance memories, A and B. When the AUTO W/B BAL switch is pushed to the WHT side, the white balance will be adjusted automatically according to the filter settings. The adjusted value will be stored in the selected memory. Each memory can store up to five adjusted values, for a total of 10.

## Setting the Electronic Shutter

This section explains the different modes which can be used for the electronic shutter and gives the procedures for setting the shutter mode and shutter speed.

### Note

When a camera control unit or a remote control device, such as MSU-1000/1500 Master Setup Unit and RCP-1000/1500-series Remote Control Panel, is connected, the electronic shutter is controlled from the external control device and control on the camera are disabled.

## About the shutter modes

The shutter modes that can be used with the electronic shutter of the camera and the shutter speeds that may be selected are as follows:

Shutter modes and speeds

Shutter mode	Shutter speeds*	Usage
Standard	1/100, 1/125, 1/250, 1/500, 1/1000, 1/2000 seconds	Use to obtain clear images of quickly moving subjects
ECS (Extended Clear Scan)	Continuously variable in the range of 60.00 Hz to 4300 Hz	Use to obtain images on video monitors without horizontal striping

\* The values in the table are those with 59.94i. With other formats, the available values are different.

### Note

With artificial lighting, particularly fluorescent lights and mercury vapor lamps, the brightness appears to be constant, but in fact the strength of the red, green, and blue components varies with the power supply frequency. This phenomenon is known as “flicker.” When using the electronic shutter under these lighting conditions, there are certain cases in which the flicker is more noticeable. In particular, color flicker is evident when the power frequency is 60 Hz. In areas where the power frequency is 50 Hz, setting the shutter speed to 1/100 second will reduce the flicker.

## Selecting the shutter mode and speed

The shutter mode, and the shutter speed in standard mode, are set using the SHUTTER switch.

## Setting the shutter mode, and shutter speed in Standard mode

- 1 Push the SHUTTER switch from the ON position to the SEL position.

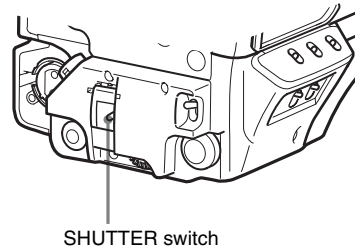

The current shutter setting will be displayed in the setting change/adjustment progress message display area of the viewfinder screen for about three seconds.

Example: “SHUTTER: 1/250”

- 2 Push the SHUTTER switch to the SEL position again before the display disappears. Repeat this action until the desired mode or speed is displayed.

When all modes and speeds are displayed, they will be displayed in the following order:

Example: with 59.94i

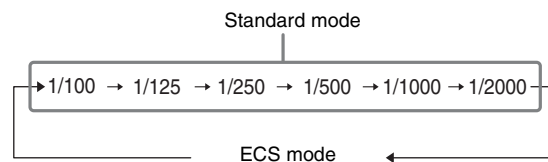

## Setting the Focus Assist Functions

Using the OPERATION menu, the assist functions for easier focusing on the viewfinder, can be activated.

### Adding the VF detail signal

Adding the VF detail signal to sharp edges in the image on the viewfinder screen makes it easier to check the focusing condition by observing changes in the detail signal or in the color converted from the detail signal (color detail). The focus setting where the detail signal becomes strongest is the best focus setting.

- 1 Turn on the camera.
- 2 Set the DISPLAY switch to MENU while holding the MENU SEL knob/ENTER button pressed. The camera enters Menu mode, and “TOP” is displayed at the upper right corner of the screen.

- 3 Rotate the MENU SEL knob/ENTER button to align the arrow marker (➔) to “TOP” and push on the MENU SEL knob/ENTER button.

The TOP MENU screen is displayed.

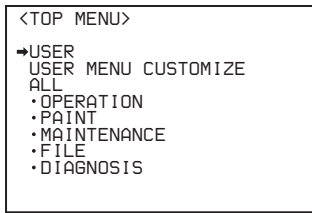

- 4 Rotate the MENU SEL knob/ENTER button to align the arrow marker (➔) to OPERATION and push on the MENU SEL knob/ENTER button.

The CONTENTS page of the OPERATION menu is displayed.

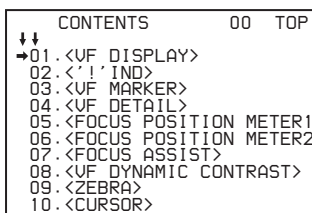

- 5 Rotate the MENU SEL knob/ENTER button to align the arrow marker (➔) to <VF DETAIL> and push on the MENU SEL knob/ENTER button.

The <VF DETAIL> page is displayed.

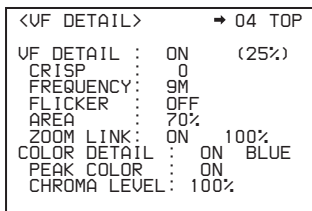

- 6 Rotate the MENU SEL knob/ENTER button to align the arrow marker (➔) to the item to be set and push on the MENU SEL knob/ENTER button.

#### To use the VF detail signal

Set VF DETAIL to ON to activate the VF detail function to add the detail signal to sharp edges in the image. You can adjust the signal level (strength) in the range of 0 to 100% (default 25%).

You can adjust the characteristics of the detail signal with the menu items below.

**CRISP:** Adjust to eliminate fine portions of the detail signal.

**FREQUENCY:** Change the detection band of sharp edges.

**FLICKER:** Turn ON/OFF the function to flicker the detail signal, which makes it easier to check the signal on a viewfinder screen.

**AREA:** To limit the area where to display the detail signal.

**ZOOM LINK:** Set the VF detail level at the full WIDE position. (The VF detail level changes according to the zoom position.)

#### To use the color detail

Set COLOR DETAIL to ON to convert the VF detail signal to a specified color. This makes it easier to check the signal on an LCD screen, including the viewfinder screen. The display color can be selected at the column next to ON.

You can adjust the coloring with the menu items below.

**PEAK COLOR:** Turn ON/OFF the function to change the color where the detail signal is strongest.

**CHROMA LEVEL:** To reduce the chroma components of the video signal (only for video signals on the viewfinder).

- 7 Rotate the MENU SEL knob/ENTER button to display the desired setting and push on the MENU SEL knob/ENTER button.

- 8 To finish the adjustment, set the DISPLAY switch to OFF to exit Menu mode.

### Displaying the focus assist indicators

The focus assist indicator function extracts the irregularities of a subject and converts the integrated values to a level indicator, which shows the focus condition.

Level indicator (its position and operations can be adjusted.)

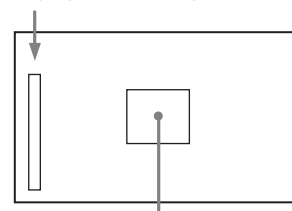

Area marker to display the detection area of the focus (its size and position can be adjusted.)

The focus setting where the indicator shows the maximum level is the best focus setting. (The range of the indicator substantially changes depending on picture elements or shooting environments. Adjust it with GAIN and OFFSET as required.)

- 1 Display the CONTENTS page of the OPERATION menu (referring to step 1 to 4 in “Adding the VF detail signal”).

- 2 Rotate the MENU SEL knob/ENTER button to align the arrow marker (➡) to <FOCUS ASSIST> and push on the MENU SEL knob/ENTER button.

The <FOCUS ASSIST> page is displayed.

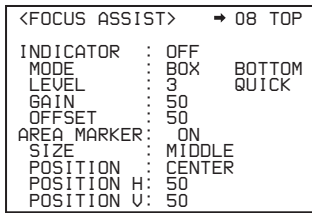

- 3 Rotate the MENU SEL knob/ENTER button to align the arrow marker (➡) to the item to be set and push on the MENU SEL knob/ENTER button.

#### To use the level indicator

Setting INDICATOR to ON displays the level indicator on the viewfinder.

You can set the display format with the menu items below.

**MODE:** Set the type and position of the indicator.

**LEVEL:** Set the density and the response speed of the indicator.

**GAIN:** Set the sensitivity of the indicator.<sup>1)</sup>

**OFFSET:** Set the offset of the focus detection value.<sup>2)</sup>

<sup>1)</sup>Normally, the sensitivity of the indicator is automatically set to the optimum value in conjunction with the AREA MARKER SIZE set value. Use this setting when an optimum sensitivity value cannot be obtained, depending on the shooting environment.

<sup>2)</sup>Normally, the optimum offset is automatically set in conjunction with the AREA MARKER SIZE and MASTER GAIN set values. Use this setting when the optimum offset cannot be obtained, depending on the shooting environment.

#### To use the area marker

Setting AREA MARKER to ON displays the detection area of the focus as a marker on the viewfinder screen.

You can set the size and position of the detection area with the menu items below.

**SIZE:** The size of the detection area can be changed. (If the area size is too large, both the subject and the background are included in the area, making the indicator display may easily deviate from the subject.)

**POSITION:** Roughly set the position of the detection area.

**POSITION H:** Finely adjust the position of the detection area in the horizontal directions.

**POSITION V:** Finely adjust the position of the detection area in the vertical directions.

- 4 Rotate the MENU SEL knob/ENTER button to display the desired setting and push on the MENU SEL knob/ENTER button.

- 5 To finish the adjustment, set the DISPLAY switch to OFF to exit Menu mode.

#### Notes

- The level indicator and the effect area marker cannot be displayed simultaneously, whichever you set to ON later is preferentially displayed.

- The area marker and the aspect safety marker cannot be displayed simultaneously, whichever you set to ON later is preferentially displayed.
- When displaying the focus assist indicators, check that the flange focal length has been precisely adjusted.

See “Adjusting the Flange Focal Length” on page 12 for the flange focal length.

## Setting the Focus Position Meter Function

The focus position meter function allows you to graphically display the registered focus position (marker) and the current focus position (index) graphically on the viewfinder screen.

Current focus position (index)

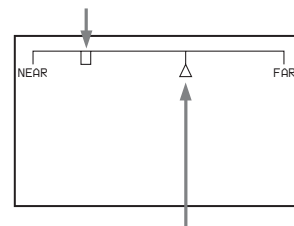

Registered focus position (marker)

You can set the focus to the registered point easily by adjusting the focus until the index position overlaps the marker position (adjusted state). In the adjusted state, you can display a color frame and marker name on the viewfinder screen.

- 1 Display the CONTENTS page of the OPERATION menu (referring to steps 1 to 4 in “Adding the VF detail signal”).
- 2 Turn the MENU SEL knob/ENTER button to align the arrow marker (➡) to <FOCUS POSITION METER1> or <FOCUS POSITION METER2>, and press the MENU SEL knob/ENTER button.

The <FOCUS POSITION METER1> page or <FOCUS POSITION METER2> page is displayed.

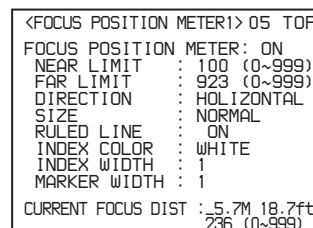

- 3 Turn the MENU SEL knob/ENTER button to align the arrow marker (➡) to the item to be set and press the MENU SEL knob/ENTER button.

#### To use the focus position meter

Setting FOCUS POSITION METER to ON displays the focus position meter on the viewfinder screen.

You can set the display format with the <FOCUS POSITION METER1> page items below.

**NEAR LIMIT:** Sets the NEAR edge of the focus position meter.

**FAR LIMIT:** Sets the FAR edge of the focus position meter.

The focus position range to display varies depending on the NEAR LIMIT and FAR LIMIT settings. The full range is displayed by setting NEAR LIMIT to 0 and FAR LIMIT to 999.

**DIRECTION:** Selects whether to display the meter horizontally at the top of the screen or vertically on the right edge of the screen.

**SIZE:** Sets the size of the meter.

**RULED LINE:** Turns the display of guide lines on the meter on/off.

**INDEX COLOR:** Sets the color of the index.

**INDEX WIDTH:** Sets the width of the index.

**MARKER WIDTH:** Sets the width of the marker.

#### To set the adjustment sensitivity and display content

You can set the adjustment sensitivity and configure the display in the adjusted state using ADJUSTED SIGN on the <FOCUS POSITION METER2> page.

**SENSE:** Sets the adjustment sensitivity. Increasing the value increases the sensitivity (making determination of adjusted state more precise).

**NAME DISP:** Turns the display of the marker name in the adjusted state on/off (DISPLAY screen only).

**FRAME DISP:** Turns the display of a color frame (adjustment frame) on the screen in the adjusted state on/off.

**FRAME WIDTH:** Sets the width of the adjustment frame.

#### To configure the marker display settings

You can set the marker display using MARKER CONFIG on the <FOCUS POSITION METER2> page.

**REG:** Registers a marker at the index position.

**DISP:** Turns the marker display on/off.

**COLOR:** Sets the color of the marker. This also sets the color of the adjustment frame.

**NAME:** Sets the name of the marker.

**POS:** Adjusts the marker position manually.

**4 Turn the MENU SEL knob/ENTER button to display the desired setting and press the MENU SEL knob/ENTER button.**

**5 To finish the adjustment, set the DISPLAY switch to OFF to exit Menu mode.**

### Marker registration

When HDLA is attached, you can register a marker for the focus position meter using the VF OUT switch. Marker 1 is registered using the R switch, marker 2 by the G switch, and marker 3 by the B switch. Setting a switch to ON registers a marker at the current index position (same function as REG on the <FOCUS POSITION METER2> page). Setting a switch to OFF turns the marker display off (same as setting DISP on the <FOCUS POSITION METER2> page to OFF).

### To register a marker for the focus position meter using the VF OUT switch

Set VF OUT SW to FOCUS POSITION METER on the <SWITCH ASSIGN1> page in the OPERATION menu.

## Setting the VF Dynamic Contract Function

Emphasizing the contrast in the image on the viewfinder screen makes it easier to check the focusing condition for high brightness areas and for subjects with low contrast levels. The function of ON/OFF can also be operated via the switches on the back panel.

- 1 Turn on the camera.**
- 2 Set the DISPLAY switch to MENU while holding the MENU SEL knob/ENTER button pressed.**  
The camera enters Menu mode, and "TOP" is displayed at the upper right corner of the screen.
- 3 Rotate the MENU SEL knob/ENTER button to align the arrow marker (→) to "TOP" and push on the MENU SEL knob/ENTER button.**  
The TOP MENU screen is displayed.

```
<TOP MENU>
→USER
USER MENU CUSTOMIZE
ALL
·OPERATION
·PAINT
·MAINTENANCE
·FILE
·DIAGNOSIS
```

- 4 Rotate the MENU SEL knob/ENTER button to align the arrow marker (→) to OPERATION and push on the MENU SEL knob/ENTER button.**  
The CONTENTS page of the OPERATION menu is displayed.

```
CONTENTS 00 TOP
↓↓
01.<VF DISPLAY>
02.<'IND>
03.<VF MARKER>
04.<VF DETAIL>
05.<FOCUS POSITION METER1>
06.<FOCUS POSITION METER2>
07.<FOCUS ASSIST>
→08.<VF DYNAMIC CONTRAST>
09.<ZEBRA>
10.<CURSOR>
```

- 5 Rotate the MENU SEL knob/ENTER button to align the arrow marker (→) to <VF DYNAMIC CONTRAST> and push on the MENU SEL knob/ENTER button.**  
The <VF DYNAMIC CONTRAST> page is displayed.

```
<VF DYNAMIC CONTRAST> 08→TOP
DYNAMIC CONTRAST: OFF
GAIN : 0%
FILTER : WIDE
MODE : HIGHLIGHT
```

- 6** Rotate the MENU SEL knob/ENTER button to align the arrow marker (→) to the item to be set and push on the MENU SEL knob/ENTER button.

**To use the VF dynamic contrast signal**

Set DYNAMIC CONTRAST to ON to add the contrast signal in the image. You can adjust the GAIN in the range of 0 to 100%.

You can adjust the characteristics of the contrast signal with the menu items below.

**FILTER:** Adjust the selection range of the contrast extraction target pixel.

**MODE:** Selection of contrast signal addition mode. HIGHLIGHT emphasizes the contrast of the high brightness range. FOGGY emphasizes the contrast of the image which is hazy and in low contrast.

- 7** Rotate the MENU SEL knob/ENTER button to display the desired setting and push on the MENU SEL knob/ENTER button.

- 8** To finish the adjustment, set the DISPLAY switch to OFF to exit Menu mode.

## Setting the Camera Outputs

You can specify video signals directly output from the camera, with menu operations.

**Notes**

- The MAIN (camera picture), RET (return video), or VF (the same picture as that displayed on the viewfinder screen) setting is common to SD-SDI and VBS. Different signals cannot be output.
- When <CAM MODE> is set to 4K/HDR MODE, DOWN CONVERTER is not available. Only the CHARACTER information is displayed when <CAM MODE> is set to 4K/HDR MODE and SD-SDI or VBS is selected.

The menu pages used for the output settings have been registered to the USER menu at the factory.

- <OUTPUT FORMAT>
- <TEST OUT>
- <SDI OUT>

Set the following menu items to the settings shown in the table.

*For details on menu operations and the USER menu, see "Menu Operations" on page 26.*

### Outputting the signal being shot (camera picture)

The same textual information as that displayed on the viewfinder screen can be added to the output signal by setting CHARACTER to "ON" on the <SDI OUT> or <TEST OUT> page.

**To output as HD-SDI**

Menu page	Item	Setting
<SDI OUT>	SDI-MONI OUT	MAIN

**To output as SD-SDI**

Menu page	Item	Setting
<SDI OUT>	SDI-MONI OUT	SD-SDI
	DOWN CONVERTER SELECT	MAIN

**To output as VBS**

Menu page	Item	Setting
<TEST OUT>	OUTPUT	VBS
	DOWN CONVERTER SELECT	MAIN

## Constantly outputting a return video

- When a camera control unit is connected, one of the signals being supplied to the camera control unit can be output from the camera.
- The last selected return signal is output.
- The same textual information as that displayed on the viewfinder screen can be added to the output signal by setting CHARACTER to “ON” on the <SDI OUT> or <TEST OUT> page.

### To output as HD-SDI

Menu page	Item	Setting
<SDI OUT>	SDI-MONI OUT	RET

### To output as SD-SDI

Menu page	Item	Setting
<SDI OUT>	SDI-MONI OUT	SD-SDI
	DOWN CONVERTER SELECT	RET

### To output as VBS

Menu page	Item	Setting
<TEST OUT>	OUTPUT	VBS
	DOWN CONVERTER SELECT	RET

## Outputting the same image as that on the viewfinder screen

- With HD-SDI, you can obtain a signal that includes the same information as that being displayed on the viewfinder screen according to the settings of the VF MARKER, CHARACTER, VF DETAIL, ZEBRA, etc. The ON/OFF or other settings for adding information are common to those for the viewfinder. The output is synchronized with switching among Y, R, G, and B or switching to a return signal.
- With SD-SDI or VBS, the output is synchronized only with switching between a return signal and the camera image. It does not correspond to switching among Y, R, G, and B. Information other than CHARACTER (such as VF MARKER, VF DETAIL, ZEBRA) cannot be added to the output.

### Note

With the settings for outputting the same image as that on the viewfinder screen, the output will be obtained in 1080i, even if the format setting is 720P.

### To output as HD-SDI

Menu page	Item	Setting
<SDI OUT>	SDI-MONI OUT	VF

### To output as SD-SDI

Menu page	Item	Setting
<SDI OUT>	SDI-MONI OUT	SD-SDI
	DOWN CONVERTER SELECT	VF

### To output as VBS

Menu page	Item	Setting
<TEST OUT>	OUTPUT	VBS
	DOWN CONVERTER SELECT	VF



# Viewfinder Screen Status Display

Besides the video image, the viewfinder can display text and messages showing the camera settings and operation status, as well as items such as a center marker or safety zone marker.

## When the DISPLAY switch is set to DISPLAY

Items set to ON using the menu or related switches will be displayed on the upper and lower edges of the screen.

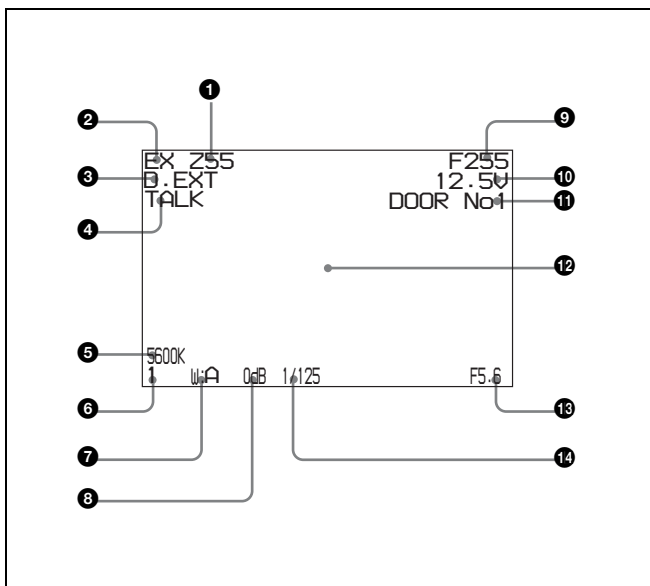

### 1 Zoom position

Indicates the approximate position of the zoom lens variator between wide angle (0) and telephoto (99). Shows how close it is to the telephoto side.

### 2 Lens extender

“EX” is displayed when a lens extender is in use.

### 3 Digital extender

“D.EXT” is displayed when a digital extender is in use.

### 4 TALK indication

Displayed when the intercom microphone is set to ON.

### 5 5600K mode

Displayed when 5600K is set to ON.

### 6 Filter

Displays the type of filter currently selected. The number (1, 2, 3, 4, or 5) indicates the ND filter.

### 7 White balance memory

Displays the currently selected white balance automatic adjustment memory.

**W:A:** The WHITE BAL switch is set to “A”

**W:B:** The WHITE BAL switch is set to “B”

**W:P:** The WHITE BAL switch is set to “PRST”

### 8 Gain value

Displays the video gain value (dB) set with the GAIN switch.

### 9 Focus position

Shows the focus position of a zoom lens as a numeric value (0 to 255 (infinity)).

## Note

Displayed only when a serial communication lens is connected.

### 10 Battery voltage

Displays the input voltage.

### 11 Marker name of the focus position meter

Displays the marker name of the focus position meter.

### 12 Setting change / adjustment process message area

This area is only used when the MESSAGE item of the menu is set to other than OFF.

### 13 F value

Indicates the lens F (iris opening) value.

### 14 Shutter/ECS

Displays the shutter/ECS status. Nothing is displayed if the electronic shutter is set to OFF.

## When you press the CANCEL/STATUS switch toward STATUS

The status display is changed to show the following items:

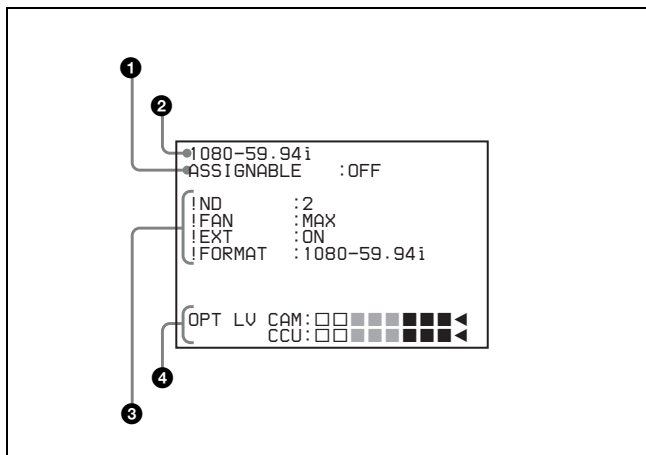

### 1 Assignable switch indication

The function assigned to the assignable switch (page 7) is indicated.

For the functions that can be assigned, see OPERATION menu <SWITCH ASSIGN1> (page 43).

### 2 Format indication

The current video format is displayed.

### 3 ‘!’ indication area

This area is used to display abnormal statuses, using the <! IND> function. Display options can be set, using the menu.

For details, see OPERATION menu <! IND> (page 38).

#### ④ Light-receiving level indications

This area shows the light-receiving levels in segments.

**CAM:** Light-receiving level at the CCU connector (page 8) of the camera

**CCU:** Light-receiving level at the CAMERA connector of the CCU

#### Note

If a camera control unit other than an HDCU1700 is connected, correct indications may not be obtained.

## Menu Operations

The menus displayed on the viewfinder screen enable various settings of the camera.

The following controls are used to operate the menus.

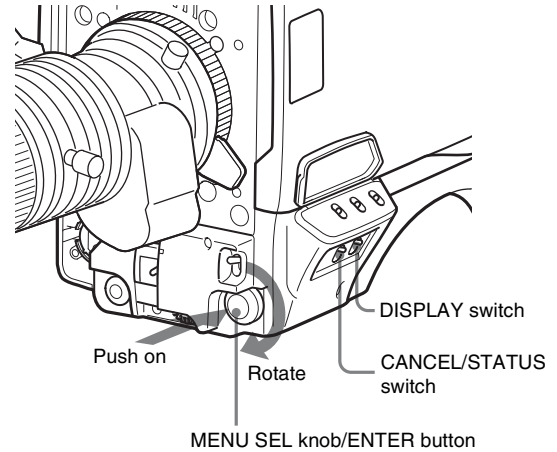

### Starting Menu Operations

#### To display a menu page

Set the DISPLAY switch from OFF to MENU.

The menu page that last operated will be displayed. (If it is the first time, the CONTENTS page of the OPERATION menu will be displayed.)

#### To display the TOP MENU screen

If you set the DISPLAY switch from OFF to MENU while holding the MENU SEL knob/ENTER button pressed, "TOP" is displayed at the upper right corner of the screen.

Selecting it displays the TOP MENU screen, which lists the available menus, and you can select the menus on this screen.

#### TOP MENU screen

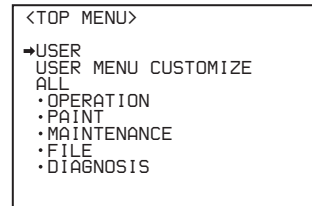

#### To disable the "TOP" indication

Turn the power once off then on again, or set the DISPLAY switch from OFF to MENU while holding the CANCEL/STATUS switch pressed toward CANCEL. This disables the TOP selection.

## Available menus

### USER menu

This menu can include menu pages selected from among the OPERATION, PAINT, MAINTENANCE, FILE, and DIAGNOSIS menus, for convenience. Changing, adding, and deleting pages can be performed with the USER MENU CUSTOMIZE menu.

### USER MENU CUSTOMIZE menu

This menu allows you to edit the USER menu.

For details on the USER menu, see "Editing the USER Menu" on page 29.

### ALL menu

This menu permits you to control all items of the OPERATION menu, PAINT menu, MAINTENANCE menu, FILE menu, and DIAGNOSIS menu as a single menu.

### OPERATION menu

This menu contains items for camera operators to operate the camera. It mainly permits viewfinder, intercom, and switch settings.

### PAINT menu

This menu contains items for making detailed image adjustments while using a waveform monitor to monitor the waveforms output from the camera. Support of a video engineer is usually required to use this menu. Although you can also use an external remote control panel or master setup unit to set the items on this menu, the menu is effective when using the camera by itself outdoors.

### MAINTENANCE menu

This menu contains items for performing camera maintenance operations, such as changing the system or setting infrequently used "paint" items.

### FILE menu

This menu is for performing file operations, such as writing or clearing the reference file.

### DIAGNOSIS menu

This menu enables you to confirm the self-diagnostic information.

## To select a menu on the TOP MENU screen

- 1 Rotate the MENU SEL knob/ENTER button to align the arrow marker (➡) with the desired menu indication.
- 2 Push on the MENU SEL knob/ENTER button.  
The CONTENTS page or the last operated page of the selected menu is displayed.

## Selecting Pages

### When selecting a page from a CONTENTS page

Example: CONTENTS page of the OPERATION menu

If the screen can be scrolled, arrows will indicate the direction of scrolling.

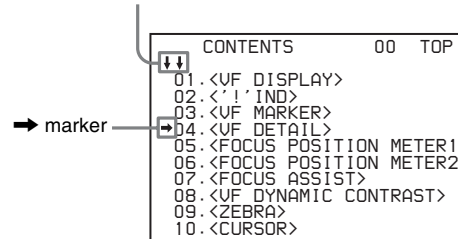

Rotate the MENU SEL knob/ENTER button to align the arrow marker (➡) with the desired page indication, then push on the MENU SEL knob/ENTER button.

The selected page is displayed.

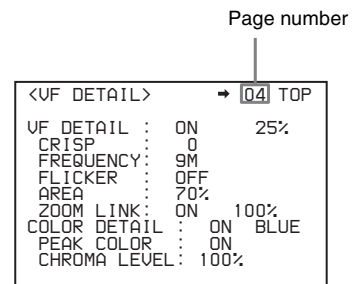

## To change the displayed page

- 1 Check that the arrow marker (➡) is located at the left of the page number, then push on the MENU SEL knob/ENTER button.

The arrow marker (➡) changes to a flashing question (?) mark.

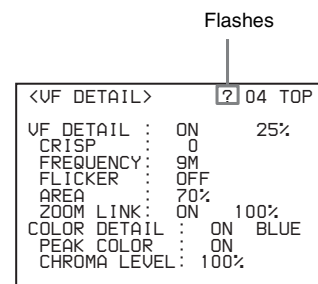

- 2 Rotate the MENU SEL knob/ENTER button to flip through the pages.**
- 3 When the desired page is displayed, push on the MENU SEL knob/ENTER button.**  
The “?” mark will change back to the arrow marker (➡), and operations with the displayed page are enabled.

#### To return to the TOP MENU screen

Align the arrow marker (➡) with “TOP” at the top right of the menu page then press the MENU SEL knob/ENTER button.

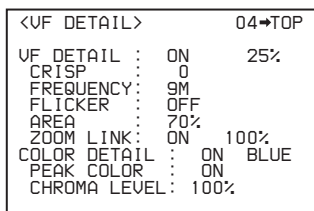

The TOP MENU screen is resumed.

## Setting the Menu Items

If a “?” mark is flashing at the left of the page number, push on the MENU SEL knob/ENTER button to change it to the arrow marker (➡). Setting on the displayed page is enabled.

- 1 Rotate the MENU SEL knob/ENTER button to align the arrow marker (➡) with the desired item.**
- 2 Push on the MENU SEL knob/ENTER button.**  
The arrow marker (➡) will change to a flashing “?” mark.
- 3 Rotate the MENU SEL knob/ENTER button to change the setting value.**  
When the knob is rotated quickly, the values will change quickly; when rotated slowly, the values will change slowly.  
**To reset a changed value**  
If you press the CANCEL/STATUS switch toward CANCEL before pressing the MENU SEL knob/ENTER button, the setting will be returned to its previous value.  
**To interrupt settings**  
Set the DISPLAY switch to OFF to turn off the menu screen display.  
The setting operation can be restarted by setting the DISPLAY switch back to MENU.
- 4 Push on the MENU SEL knob/ENTER button.**  
The “?” mark will change back to the arrow marker (➡), and the new setting will be registered.
- 5 To change other setting items on the same menu page, repeat steps 1 through 4.**

#### To specify a character string

When you press the MENU SEL knob/ENTER button with the arrow marker (➡) pointing to an item for which a character string, such as a file ID, is to be specified, a cursor and the list of selectable characters are displayed.

The displayed cursor can be moved by rotating the MENU SEL knob/ENTER button.

- 1 Set the cursor to the position where you wish enter a character, then push on the MENU SEL knob/ENTER button.**  
Another cursor appears on the character list.
- 2 Set the cursor to the character to be entered and push on the MENU SEL knob/ENTER button.**  
Repeat steps 1 and 2.

By selecting INS on the line below the character list, you can enter a space at the cursor position.

Selecting DEL deletes the character at the cursor position.

You can return to step 1 without changing the character by selecting RET.

If you enter the permitted maximum number of characters (up to the stop mark at the right end of the line), the cursor moves to ESC on the line below the character list.

To register the new string you have set, select END and push on the MENU SEL knob/ENTER button.

To restore the previous string, select ESC and push on the MENU SEL knob/ENTER button.

#### To return a menu item to its standard value

Select the menu item to be returned to its standard value then hold the MENU SEL knob/ENTER button pressed for 3 seconds while the arrow marker (➡) is displayed. If “10 SEC CLEAR” has been set to ON on the <FILE CLEAR> page of the FILE menu, you can return the setting in the reference file for the item being selected to the factory-set value by holding the MENU SEL knob/ENTER button pressed for another 10 seconds.

#### To end menu operations

Set the DISPLAY switch to OFF.

## Editing the USER Menu

You can select desired pages and items from the OPERATION, PAINT, MAINTENANCE, FILE, and DIAGNOSIS menus and register them to the USER menu. If you specify pages or items frequently used for the USER menu, you can easily call and use them.

The following pages are included on the factory-set USER menu:

Menu page title	USER menu No.	Source menu / page No.
<VF OUT>	U01	OPERATION 13
<VF DETAIL>	U02	OPERATION 04
<FOCUS ASSIST>	U03	OPERATION 07
<VF DISPLAY>	U04	OPERATION 01
<! IND>	U05	OPERATION 02
<VF MARKER>	U06	OPERATION 03
<CURSOR>	U07	OPERATION 10
<ZEBRA>	U08	OPERATION 09
<SWITCH ASSIGN1>	U09	OPERATION 14
<SWITCH ASSIGN2>	U10	OPERATION 15
<HEADSET MIC>	U11	OPERATION 18
<OUTPUT FORMAT>	U12	MAINTENANCE M10
<TEST OUT>	U13	MAINTENANCE M11
<SDI OUT>	U14	MAINTENANCE M12
<ROM VERSION>	U15	DIAGNOSIS D03

For the items on each page, see the corresponding source menu page in the table in "Menu List" on page 32.

The USER MENU CUSTOMIZE menu allows you to configure a USER menu that consists only of pages and items that you need, by your adding, deleting or replacing pages.

### Editing by items

The USER MENU CUSTOMIZE menu allows you to add a new page to the USER menu and add desired items to the page. While the EDIT page contains factory-preset items, the USER 1 EDIT to USER 19 EDIT pages are all blank in their initial state. You can register up to 10 items, including blank lines, on each of these pages.

### To add items to a page

Proceed as follows.

- 1 Set the DISPLAY switch from the OFF position to the MENU position while holding the MENU SEL knob/ENTER button pressed.

The TOP MENU screen appears.

- 2 Turn the MENU SEL knob/ENTER button to move the arrow marker (→) to "USER MENU CUSTOMIZE" then push on the MENU SEL knob/ENTER button. If this is the first time the USER MENU CUSTOMIZE menu has been displayed, the CONTENTS page of the menu appears.

```

CONTENTS      E00 TOP
↓↑
01.EDIT PAGE
02.USER 1 EDIT
→03.USER 2 EDIT
04.USER 3 EDIT
05.USER 4 EDIT
06.USER 5 EDIT
07.USER 6 EDIT
08.USER 7 EDIT
09.USER 8 EDIT
10.USER 9 EDIT
    
```

If the USER MENU CUSTOMIZE menu has been used before, the page last accessed appears.

- 3 If the CONTENTS page is displayed, turn the MENU SEL knob/ENTER button to move the arrow marker (→) to any of USER 1 EDIT to USER 19 EDIT then push on the MENU SEL knob/ENTER button to display the page.

If a different page is displayed, turn the MENU SEL knob/ENTER button until the desired page appears, then push on the MENU SEL knob/ENTER button to select the page.

Example: When you select the USER 2 EDIT page

```

USER 2 EDIT   E03 TOP
→
    
```

- 4 Move the arrow marker (→) to the item to be added (this operation is unnecessary if no item exists on the page, as shown in the figure for step 3) then push on the MENU SEL knob/ENTER button.

The EDIT FUNCTION screen appears.

```

EDIT FUNCTION  ESC
→INSERT
MOVE
DELETE
BLANK
    
```

- 5 Move the arrow marker (→) to "INSERT" and push on the MENU SEL knob/ENTER button.

The page with the last item added appears.

```

<SW STATUS>    P01 ESC
FLARE      :→ ON
GAMMA      : ON
BLK GAM    : OFF
KNEE       : ON
WHT CLIP   : ON
DETAIL     : ON
LVL DEP    : ON
SKIN DTL   : OFF
MATRIX     : OFF
    
```

## 6 Add the items.

- ① Turn the MENU SEL knob/ENTER button until the page that has the desired items appears then push on the MENU SEL knob/ENTER button.
- ② Turn the MENU SEL knob/ENTER button to move the arrow marker (➡) to the desired item then push on the MENU SEL knob/ENTER button.

The USER 2 EDIT page appears again, displaying the newly added item.

## 7 Add the remaining items by repeating steps 4 to 6. You can add up to 10 items on one page.

### To delete items from a page

Proceed as follows:

- 1 Move the arrow marker (➡) to the item to be deleted, and push on the MENU SEL knob/ENTER button.**  
The EDIT FUNCTION screen appears.
- 2 Select “DELETE,” and push on the MENU SEL knob/ENTER button.**  
The previously displayed page appears again, and the message “DELETE OK? YES➡NO” appears at the upper right.
- 3 To delete, turn the MENU SEL knob/ENTER button to move the arrow marker (➡) to “YES,” and push on the MENU SEL knob/ENTER button.**

### To change the order of items on a page

Proceed as follows:

- 1 Turn the MENU SEL knob/ENTER button to move the arrow marker (➡) to the item to be moved then push on the MENU SEL knob/ENTER button.**  
The EDIT FUNCTION screen appears.
- 2 Select MOVE then push on the MENU SEL knob/ENTER button.**  
The previously displayed page appears again.
- 3 Turn the MENU SEL knob/ENTER button to move the arrow marker (➡) to the position where you wish to move the item then push on the MENU SEL knob/ENTER button.**

ITEM MOVE		ESC
↕↕		
➡UF OUT	: COLOR	
UF DETAIL	: OFF	
MARKER	: ON	
CURSOR	: OFF	
ZEBRA SW	: OFF	
●ASSIGNABLE	: OFF	

The item selected in step 1 moves to the position that you selected in step 3.

In the above example, “ASSIGNABLE” is moved to the top and the other items are moved down one line.

### To insert a blank line

Proceed as follows:

- 1 Turn the MENU SEL knob/ENTER button to move the arrow marker (➡) to the item above which you wish to insert a blank line.**  
The EDIT FUNCTION screen appears.
- 2 Select “BLANK” then push on the MENU SEL knob/ENTER button.**  
The previously displayed page appears again, and a blank line is inserted above the specified item.

#### Note

You cannot insert a blank line on a page where 10 items have already been registered.

### Editing by pages

You can add a page to the USER menu, delete a page from the USER menu, or replace pages, using the EDIT PAGE of the USER MENU CUSTOMIZE menu.

### To add a page

Proceed as follows:

- 1 Select “USER MENU CUSTOMIZE” on the TOP MENU screen.**  
If this is the first time the USER MENU CUSTOMIZE menu has been displayed, the CONTENTS page of the menu appears. If the menu has been used before, the last accessed page appears.
- 2 If the CONTENTS page is displayed, turn the MENU SEL knob/ENTER button to move the arrow marker (➡) to “EDIT PAGE” then push on the MENU SEL knob/ENTER button to display the EDIT PAGE screen. If a different page is displayed, turn the MENU SEL knob/ENTER button until the EDIT PAGE screen appears, then push on the MENU SEL knob/ENTER button to select the page.**

EDIT PAGE		E01 TOP
↕↕		
01.<UF OUT>		
➡02.<UF DETAIL>		
03.<FOCUS ASSIST>		
04.<UF DISPLAY>		
05.<‘!’ IND>		
06.<UF MARKER>		
07.<CURSOR>		
08.<ZEBRA>		
09.<SWITCH ASSIGN1>		
10.<SWITCH ASSIGN2>		

- 3 Turn the MENU SEL knob/ENTER button to move the arrow marker (➡) to where you wish to add the page, then push on the MENU SEL knob/ENTER button.**  
The EDIT FUNCTION screen appears.

EDIT FUNCTION		ESC
➡INSERT		
MOVE		
DELETE		

**4** Select **INSERT** then push on the **MENU SEL knob/ENTER** button.

The selection screen appears.

```
CONTENTS          ESC
↓↓
→01.USER 1
02.USER 2
03.USER 3
04.USER 4
05.USER 5
06.USER 6
07.USER 7
08.USER 8
09.USER 9
10.USER 10
```

**5** Turn the **MENU SEL knob/ENTER** button to move the arrow marker (➡) to the desired page, then push on the **MENU SEL knob/ENTER** button.

This adds the number and name of the selected page above the item selected in step 3.

**To cancel addition of a page**

Before pushing the **MENU SEL knob/ENTER** button in step 5, turn the **MENU SEL knob/ENTER** button to move the arrow marker (➡) to “ESC” at the top right of the screen, then push on the **MENU SEL knob/ENTER** button. The **EDIT PAGE** screen appears again.

**To delete a page**

Proceed as follows:

**1** On the **EDIT PAGE** screen of the **USER MENU CUSTOMIZE** menu, move the arrow marker (➡) to the page to be deleted, and push on the **MENU SEL knob/ENTER** button.

The **EDIT FUNCTION** screen appears.

**2** Select “**DELETE**” then push on the **MENU SEL knob/ENTER** button.

The previously displayed page appears again, and the message “**DELETE OK? YES➡NO**” appears at the upper right.

```
ITEM DELETE      ESC
DELETE OK? YES➡NO
01.<VF OUT>
02.<VF DETAIL>
03.<FOCUS ASSIST>
●04.<VF DISPLAY>
05.<'!' IND>
06.<VF MARKER>
07.<CURSOR>
08.<ZEBRA>
09.<SWITCH ASSIGN1>
10.<SWITCH ASSIGN2>
```

**3** To delete, turn the **MENU SEL knob/ENTER** button to move the arrow marker (➡) to “**YES**,” then push on the **MENU SEL knob/ENTER** button.

**To move a page**

Proceed as follows:

**1** Display the **EDIT PAGE** screen of the **USER MENU CUSTOMIZE** menu. Turn the **MENU SEL knob/ENTER** button to move the arrow marker (➡) to the page that you wish to move.

The **EDIT FUNCTION** screen appears.

**2** Select “**MOVE**” then push on the **MENU SEL knob/ENTER** button.

The **EDIT PAGE** screen appears again.

**3** Turn **MENU SEL knob/ENTER** button to move the arrow marker (➡) to the position to which you wish to move the page selected in step 1.

```
ITEM MOVE        ESC
↓↓
01.<VF OUT>
02.<VF DETAIL>
03.<FOCUS ASSIST>
→04.<VF DISPLAY>
05.<'!' IND>
06.<VF MARKER>
07.<CURSOR>
08.<ZEBRA>
●09.<SWITCH ASSIGN1>
10.<SWITCH ASSIGN2>
```

**4** Push on the **MENU SEL knob/ENTER** button.

The page selected in step 1 is moved to the position selected in step 3.

In the above example, <ZEBRA> moves to the “04” position, and the <VF DISPLAY> and following pages move down one line.

# Menu List

This section shows the menus to be displayed on the viewfinder screen in tables.

- For the pages that have been registered in the USER menu at the factory, the USER menu page numbers are indicated in parenthesis in the No. column of the tables.
- A CONTENTS page (numbered 00) is also provided for each menu.

## Notes

**HDLA:** HDLA1500-series Large Lens Adaptor

**CCU:** HDCU1700 Camera Control Unit

**Bold values (e.g. ON, OFF, 0):** Default settings

**Execute via ENTER:** Execute by pushing on the MENU SEL knob/ENTER button.

## Menu Tree

### OPERATION menu

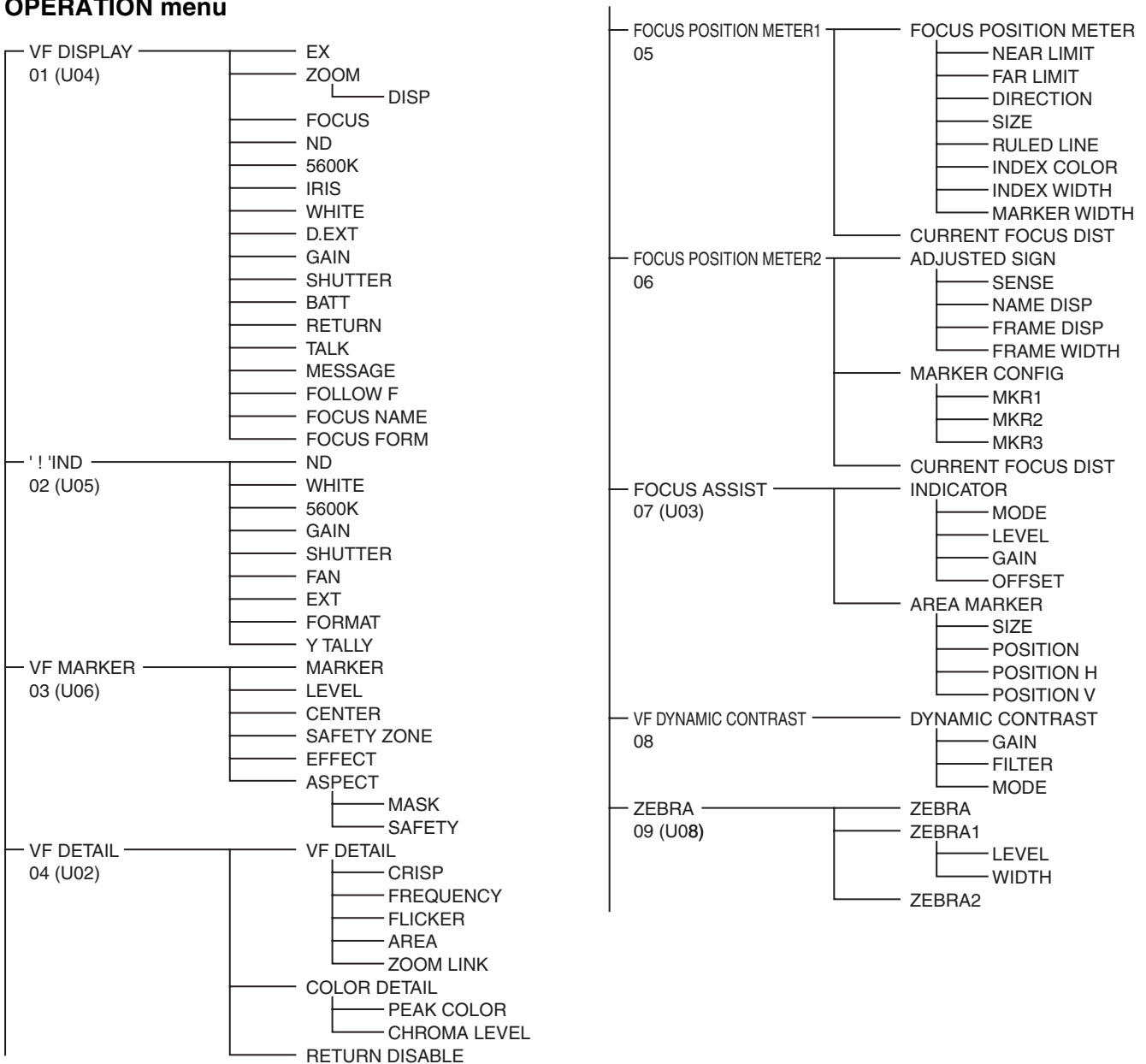



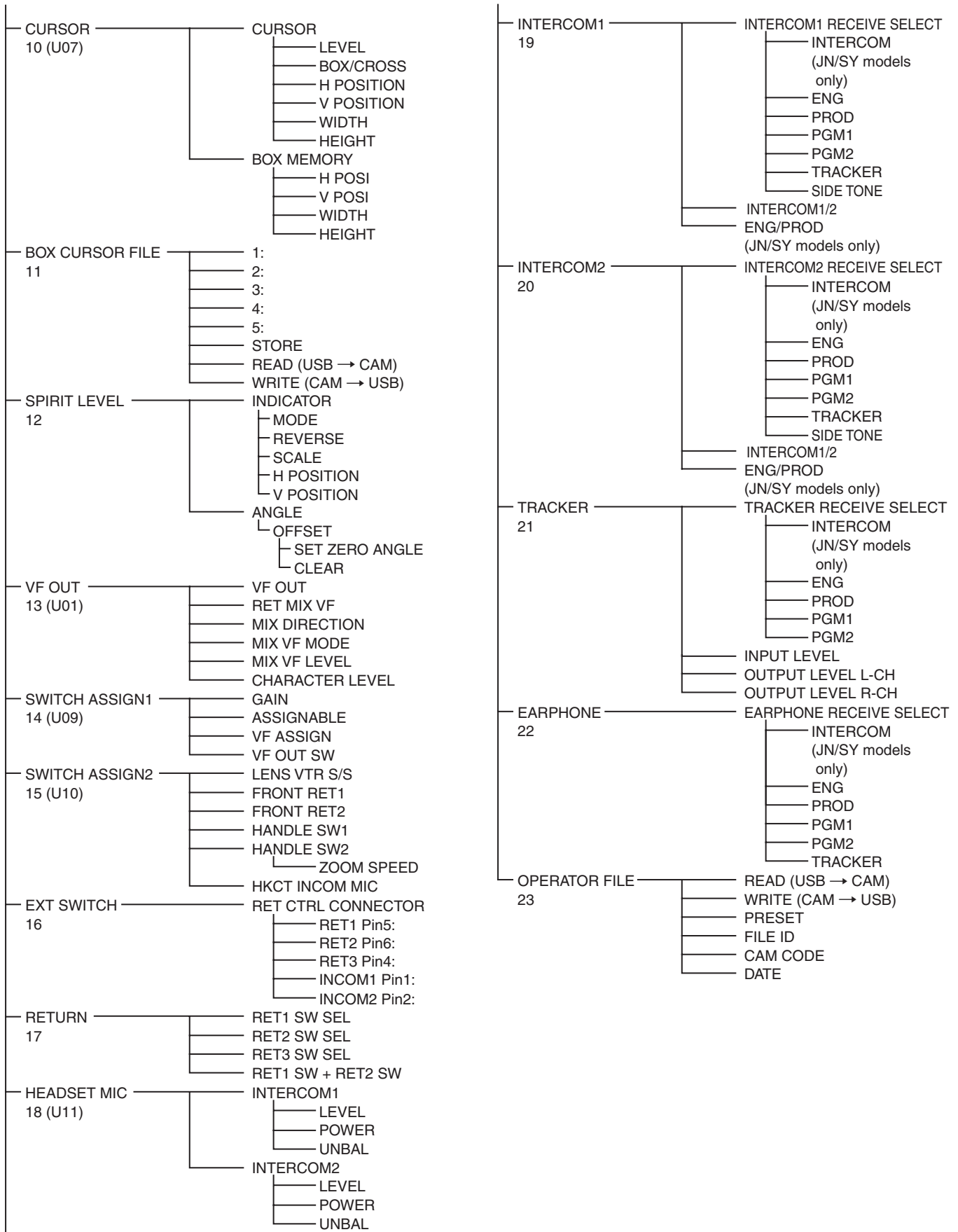

# PAINT menu

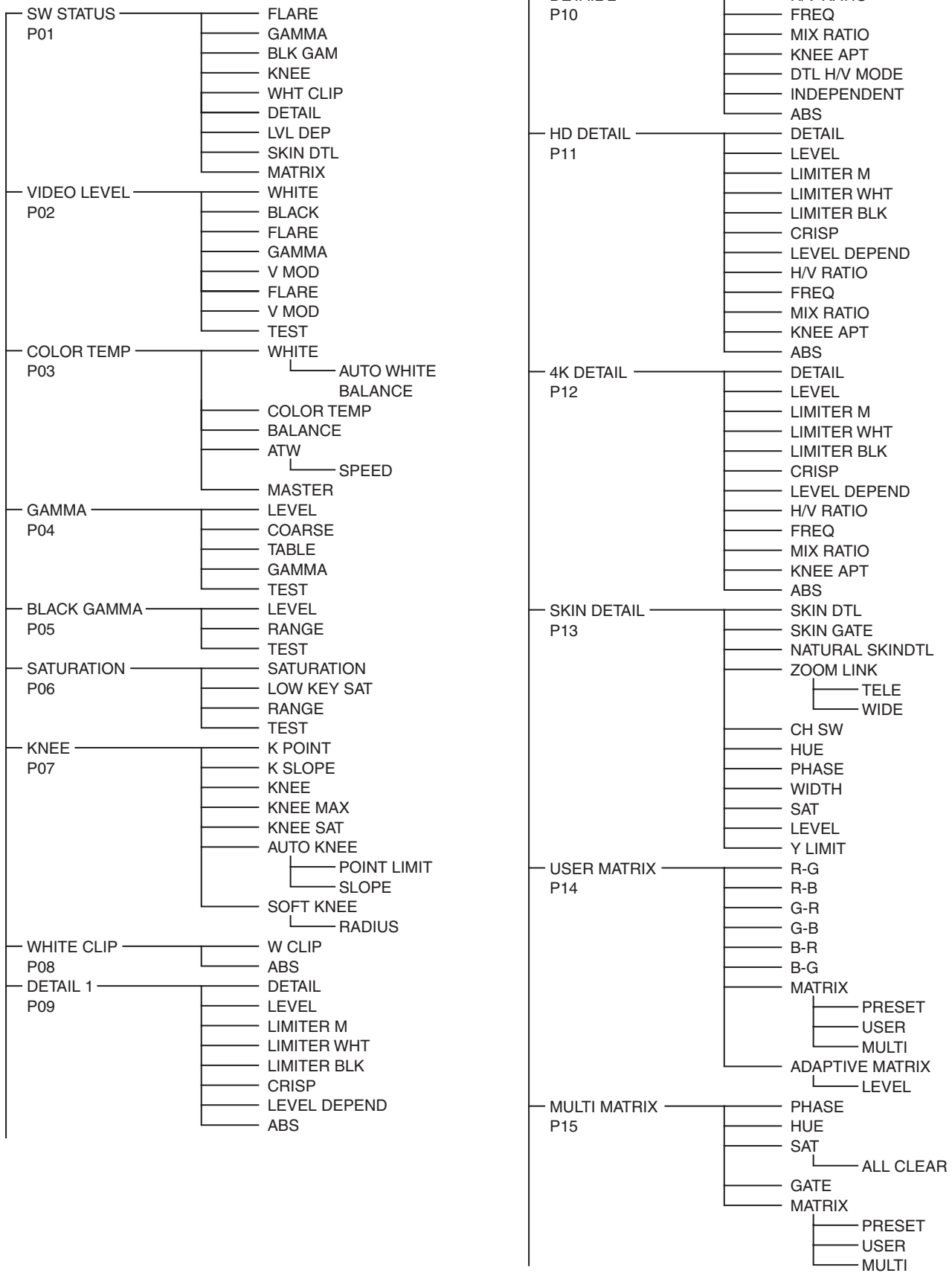

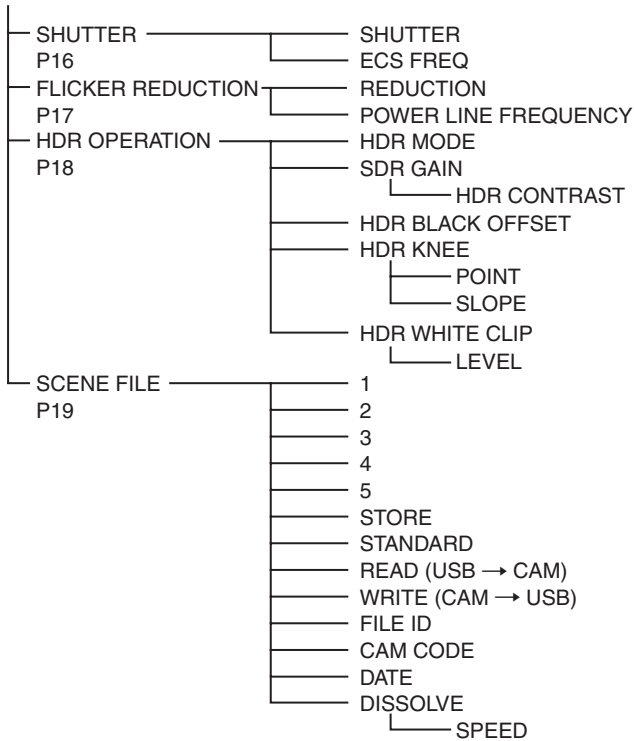

**MAINTENANCE menu**

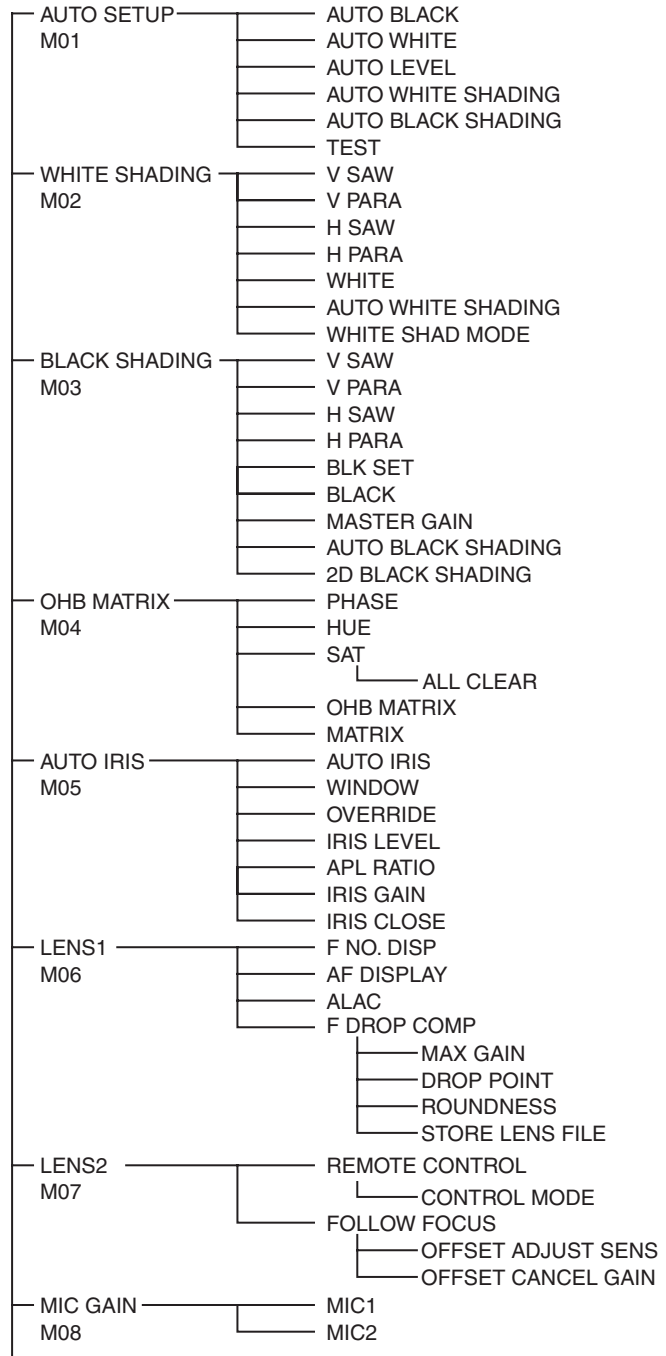

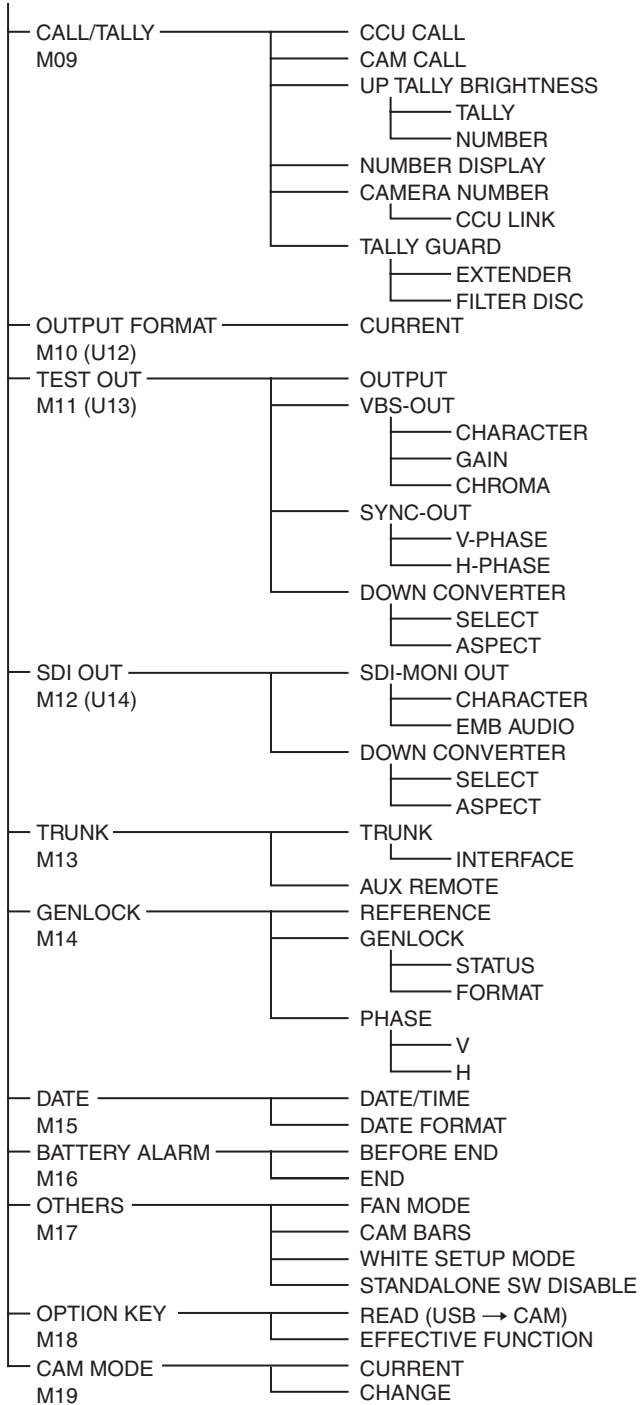

## FILE menu

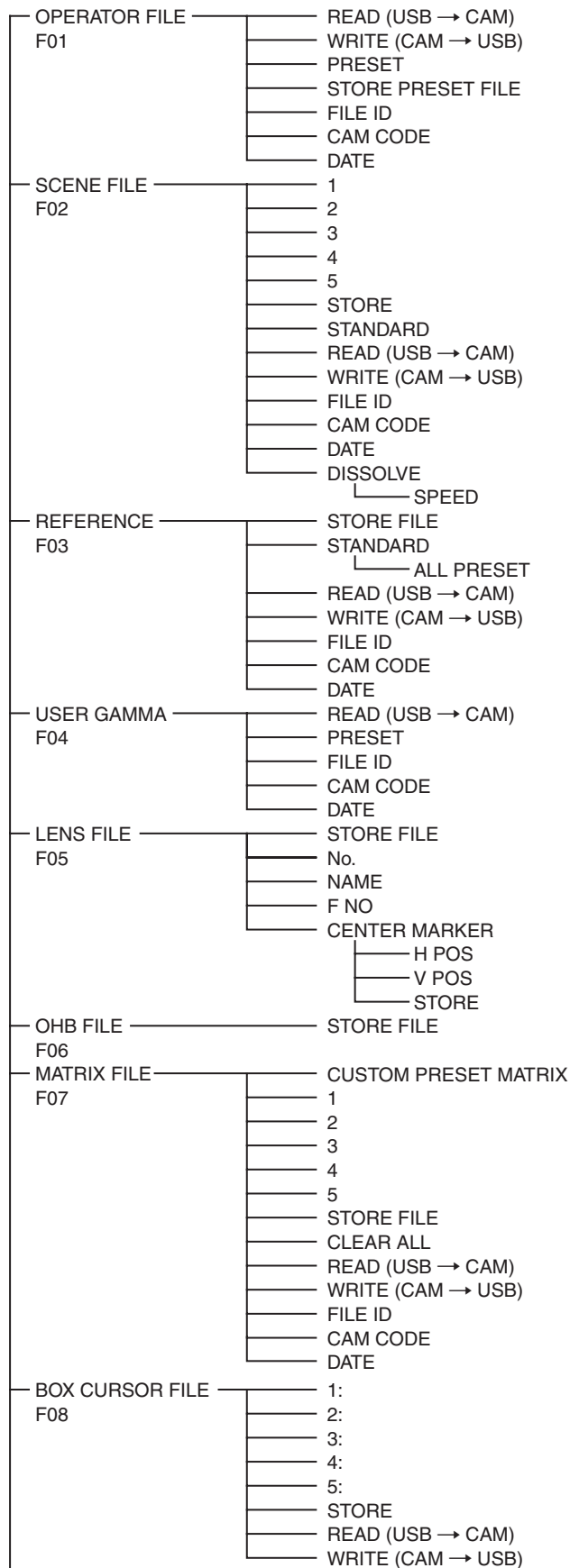

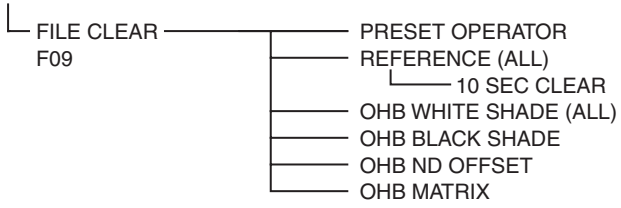

## DIAGNOSIS menu

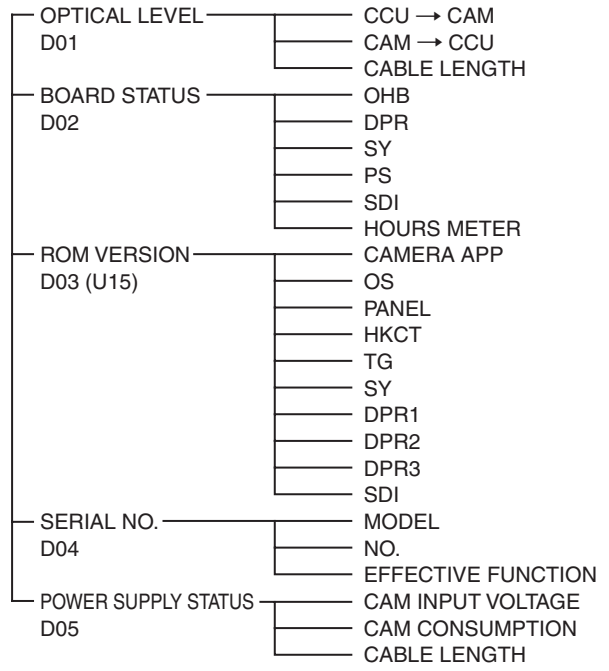

## OPERATION Menu

OPERATION				
Page title PageNo.	Item	Settings	Description	
<VF DISPLAY> 01 (U04)	EX	<b>ON</b> , OFF, 3S		
	ZOOM	ON, <b>OFF</b> , 3S		
	DISP	<b>LEFT</b> , RIGHT		
	FOCUS	ON, <b>OFF</b> , 3S	Valid only when a serial lens is used.	
	ND	<b>ON</b> , OFF, 3S		
	5600K	<b>ON</b> , OFF, 3S		
	IRIS	<b>ON</b> , OFF, 3S		
	WHITE	ON, <b>OFF</b> , 3S		
	D.EXT	<b>ON</b> , OFF, 3S		
	GAIN	<b>ON</b> , OFF, 3S		
	SHUTTER	<b>ON</b> , OFF, 3S		
	BATT	ON, <b>OFF</b> , 3S		
	RETURN	<b>ON</b> , OFF, 3S		
	TALK	<b>ON</b> , OFF, 3S		
	MESSAGE	<b>ALL</b> , WRN, AT, OFF	<b>ALL</b> : Displays all messages. <b>WRN</b> : Displays warning messages and higher. <b>AT</b> : Displays Auto Setup information and higher.	
	FOLLOW F	ON, <b>OFF</b> , 3S		
	FOCUS NAME	OFF, 1S, 3S, 5S, <b>ON</b>	Displays/hides Marker Name, and sets the display time.	
	FOCUS FORM	<b>NORMAL</b> , ABS(AUTO), ABS(m), ABS(ft)	Sets the FOCUS display format. <b>NORMAL</b> : Displayed in the range 0 to 255 (no units). <b>ABS(AUTO)</b> : Displayed in the units (meters or feet) set on the lens. <b>ABS(m)</b> : Displayed in meters. <b>ABS(ft)</b> : Displayed in feet.	
	<'!IND> 02 (U05)	ND	<b>ON</b> , OFF 1, 2, 3, 4, 5 (combination allowed)	[IND]: Sets whether to be included in the status indications on the viewfinder screen ( <i>see page 25</i> ). [NORMAL]: Specifies the conditions under which the '!' indication is not to be displayed even if [IND] is ON. (By specifying the standard or normal conditions here, non-standard or abnormal conditions can be found with the '!' indication on the viewfinder screen.)
		WHITE	<b>ON</b> , OFF, --- P, <b>A</b> , <b>B</b> (combination allowed)	
5600K		<b>ON</b> , OFF, --- <b>ON</b> , <b>OFF</b>		
GAIN		<b>ON</b> , OFF, --- <b>L</b> , M, H (combination allowed)	e.g.: With the default setting of ND, the '!' indication is displayed when an ND filter other than 1 is selected.	
SHUTTER		<b>ON</b> , OFF, --- <b>ON</b> , <b>OFF</b>	--- : When a CCU is connected (cannot be changed)	
FAN		<b>ON</b> , OFF <b>AUTO1</b> , AUTO2, MIN, MAX		
EXT		<b>ON</b> , OFF		
FORMAT		<b>ON</b> , OFF <b>1080-59.94i</b> , 1080-50i, 720-59.94P, 720-50P		
Y TALLY		<b>ON</b> , OFF		

OPERATION				
Page title PageNo.	Item	Settings	Description	
<VF MARKER> 03 (U06)	MARKER	<b>ON</b> , OFF <b>WHITE</b> , BLACK, DOT	Sets MARKER to ON/OFF.	
	LEVEL	0 to 100%, <b>40%</b>		
	CENTER	ON, <b>OFF</b> 1, 2, 3, 4	1: Entire cross 2: Entire cross with a hole 3: Center 4: Center with a hole	
	SAFETY ZONE	ON, <b>OFF</b> 80.0, <b>90.0</b> , 92.5, 95.0%		
	EFFECT	ON, <b>OFF</b> , OFF(ASSIST IND), OFF(AF DISP)	<b>OFF(ASSIST IND)</b> : Displayed when INDICATOR of <FOCUS ASSIST> is ON. <b>OFF(AF DISP)</b> : Displayed when AF DISPLAY of <LENS1> is ON.	
	ASPECT		ON, <b>OFF</b> 16:9, 15:9, 14:9, 13:9, <b>4:3</b> , (4.3)	<b>(4.3)</b> : If VF SCAN is set to 4:3 when HDLA is attached (cannot be changed)
		MASK	ON, <b>OFF</b> , (ON) 0 to 15, <b>12</b>	<b>(ON)</b> : If VF SCAN is set to 4:3 when HDLA is attached (cannot be changed). Sets the level to darken outside the aspect area.
		SAFETY	ON, <b>OFF</b> , (AREA) 80.0, <b>90.0</b> , 92.5, 95.0%	For the safety marker in Aspect mode. <b>(AREA)</b> : Displayed when AREA MARKER of <FOCUS ASSIST> is ON.
		VF DETAIL	<b>ON</b> , OFF, (ON), (OFF) 0 to 100%, (0 to 100%), <b>25%</b>	Settings in ( ): When HDLA is attached (cannot be changed)
	<VF DETAIL> 04 (U02)	CRISP	-99 to +99, <b>0</b>	
		FREQUENCY	<b>9M</b> , 14M, 18M	
		FLICKER	ON, <b>OFF</b>	
AREA		10 to 100%, <b>100%</b>		
ZOOM LINK		<b>ON</b> , OFF 0 to 100%, <b>50%</b>		
COLOR DETAIL		ON, <b>OFF</b> <b>BLUE</b> , RED, YELLOW		
PEAK COLOR		ON, <b>OFF</b>		
CHROMA LEVEL		100%, 50%, <b>25%</b> , 0%		
RETURN DISABLE	ON, <b>OFF</b>	Selects whether to set VF DETAIL to OFF for RETURN display.		

OPERATION				
Page title PageNo.	Item	Settings	Description	
<FOCUS POSITION METER1> 05	FOCUS POSITION METER	<b>OFF</b> , ON	Displays/hides the focus position meter.	
	NEAR LIMIT	<b>0</b> to 999	Sets the NEAR limit of the focus position meter.	
	FAR LIMIT	0 to <b>999</b>	Sets the FAR limit of the focus position meter.	
	DIRECTION	<b>HORIZONTAL</b> , VERTICAL	Sets the display direction of the focus position meter. <b>HORIZONTAL</b> : Displayed horizontally on the top of the screen. <b>VERTICAL</b> : Displayed vertically on the right of the screen.	
	SIZE	<b>NORMAL</b> , HALF	Sets the display size of the focus position meter.	
	RULED LINE	<b>OFF</b> , ON	Displays/hides Ruled Line.	
	INDEX COLOR	BLACK, <b>WHITE</b>	Sets the color of Index.	
	INDEX WIDTH	<b>1</b> to 5	Sets the width of Index.	
	MARKER WIDTH	<b>1</b> to 9	Sets the width for an axle of the marker.	
		CURRENT FOCUS DIST		Displays the current focus distance (display only).
<FOCUS POSITION METER2> 06	ADJUSTED SIGN			
	SENSE	1 to 5, <b>2</b>	Sets the sensitivity for the ADJUST decision. The higher the value, the higher the sensitivity.	
	NAME DISP	OFF, 1S, 3S, 5S, <b>ON</b>	Displays/hides Marker Name, and sets the display time.	
	FRAME DISP	OFF, 1S, 3S, 5S, <b>ON</b>	Displays/hides Adjust Frame, and sets the display time.	
	FRAME WIDTH	1 to 5, <b>2</b>	Sets the width of Adjust Frame.	
		MARKER CONFIG		
		[REG] MKR1, 2, 3	Execute via ENTER.	Registers the marker on the current focus position. (This item is not available when the marker registering operation is assigned to the dedicated switch.)
		[DISP] MKR1, 2, 3	<b>OFF</b> , ON	Displays/hides the marker. (This item is not available when the marker registering operation is assigned to the dedicated switch.)
		[COLOR] MKR1, 2, 3	<b>RED</b> , GREEN, BLUE, YELLOW, ORANGE, PURPLE, GRAY, BLACK, WHITE	Sets the color for the triangular area of the marker. (This item is not available when the marker registering operation is assigned to the dedicated switch.)
		[NAME] MKR1, 2, 3	Up to 8 characters (default setting: MARKER 1 to 3)	Sets the character of Marker Name. <i>See "To specify a character string" on page 28.</i>
	[POS] MKR1, 2, 3	<b>0</b> to 999	Sets the position of Marker.	
	CURRENT FOCUS DIST		Displays the current focus distance (display only).	



OPERATION				
Page title PageNo.	Item	Settings	Description	
<FOCUS ASSIST> 07 (U03)	INDICATOR	ON, <b>OFF</b> , OFF(EFFECT), OFF(AF DISP)	<b>OFF(EFFECT)</b> : Displayed when EFFECT of <VF MARKER> is ON. <b>OFF(AF DISP)</b> : Displayed when AF DISPLAY of <LENS1> is ON.	
	MODE	<b>BOX</b> , B&W, COL <b>BTM</b> , LEFT, TOP, RIGHT		
	LEVEL	0 to 100%, <b>40%</b> <b>QUICK</b> , SMOOTH		
	GAIN	0 to 99, <b>50</b>		
	OFFSET	0 to 99, <b>50</b>		
	AREA MARKER	ON, <b>OFF</b> , (ASPECT)	<b>(ASPECT)</b> : Displayed when ASPECT SAFETY of <VF MARKER> is ON.	
	SIZE	SMALL, <b>MIDDLE</b> , LARGE		
	POSITION	LEFT, <b>CENTER</b> , RIGHT		
	POSITION H	0 to 99, <b>50</b>		
	POSITION V	0 to 99, <b>50</b>		
	<VF DYNAMIC CONTRAST> 08	DYNAMIC CONTRAST	ON, <b>OFF</b> , (OFF)	<CAM MODE> The menu screen is only displayed when in 4K/HDR MODE. The menu screen is not displayed when in NORMAL MODE. <OUTPUT FORMAT> Display (OFF) except when in 1080/50P(4K/HDR) or 1080/59.94P(4K/HDR)
		GAIN	<b>0</b> to 100%, 25%	
		FILTER	<b>WIDE</b> , NARROW	
MODE		<b>HIGHLIGHT</b> , FOGGY		
<ZEBRA> 09 (U08)	ZEBRA	ON, <b>OFF</b> <b>1</b> , 2, 1&2		
	ZEBRA1			
	LEVEL	50 to 109%, <b>70%</b>		
	WIDTH	0 to 30%, <b>10%</b>		
	ZEBRA2	50 to 109%, <b>100%</b>		
<CURSOR> 10 (U07)	CURSOR	ON, <b>OFF</b>	Displayed only if HDLA attached.	
	LEVEL	<b>WHITE</b> , BLACK, DOT 0 to 100%, <b>40%</b>		
	BOX/CROSS	<b>BOX</b> , CROSS		
	H POSITION	0 to 99, <b>50</b>	Displayed only if HDLA attached.	
	V POSITION	0 to 99, <b>50</b>		
	WIDTH	0 to 99, <b>50</b>		
	HEIGHT	0 to 99, <b>50</b>		
	BOX MEMORY	1/2/3: <b>OFF</b> , ON		
	H POSI	1/2/3: 0 to 99, <b>50</b>		
	V POSI	1/2/3: 0 to 99, <b>50</b>		
	WIDTH	1/2/3: 0 to 99, <b>50</b>		
	HEIGHT	1/2/3: 0 to 99, <b>50</b>		

OPERATION			
Page title PageNo.	Item	Settings	Description
<BOX CURSOR FILE> 11	1:		Selects BOX CURSOR FILE and enters a BOX CURSOR FILE name.
	2:		Sets the cursor to the left of the number when you select BOX CURSOR FILE.
	3:		
	4:		Sets the cursor to the right of the number when you enter a BOX CURSOR FILE name.
	5:		
			<i>See "To specify a character string" on page 28.</i>
	STORE		Stores a BOX CURSOR FILE name in the camera.
	READ (USB → CAM)		Transfers BOX CURSOR FILE from a USB drive to the camera.
	WRITE (CAM → USB)		Transfers BOX CURSOR FILE from the camera to a USB drive.
<SPIRIT LEVEL> 12	INDICATOR	ON, <b>OFF</b>	When this is set to ON, BOX MEMORY for CURSOR does not function.
	MODE	<b>1</b> , 2	Switches the display method of the indicator.
	REVERSE	<b>OFF</b> , ON	Inverts the movement of the indicator horizontally.
	SCALE	50% to 150%, <b>100%</b>	Adjusts the horizontal width of the indicator.
	H POSITION	0 to 99, <b>50</b>	
	V POSITION	0 to 99, <b>97</b>	
	ANGLE		Sets the inclination angle. (Display only)
	OFFSET	-90 to +90, <b>0</b>	
	SET ZERO ANGLE	Execute via ENTER.	Designates the current angle as level (0°).
	CLEAR	Execute via ENTER.	Sets OFFSET to 0.
<VF OUT> 13 (U01)	VF OUT	<b>COLOR</b> , Y, R, G, B, (COLOR), (Y), (R), (G), (B), (RET), (R+G), (R+B), (G+B)	Settings in ( ): When HDLA is attached (cannot be changed)
	RET MIX VF	ON, <b>OFF</b> , (ON), (OFF)	Settings in ( ): When HDLA is attached (cannot be changed)
	MIX DIRECTION	MAIN, <b>RET</b>	
	MIX VF MODE	<b>Y-MIX</b> , Y/C-MIX, WIRE(W), WIRE(B)	
	MIX VF LEVEL	0 to <b>99%</b>	
	CHARACTER LEVEL	1 to 5, <b>4</b>	

OPERATION			
Page title PageNo.	Item	Settings	Description
<SWITCH ASSIGN1> 14 (U09)	GAIN	L: -6, -3, <u>0</u> , 3, 6, 9, 12 dB M: -6, -3, 0, 3, <u>6</u> , 9, 12 dB H: -6, -3, 0, 3, 6, 9, <u>12</u> dB	
	ASSIGNABLE	<b>OFF</b> , RETURN1 SW, RETURN2 SW, INCOM1, INCOM2, VF DETAIL, MIX VF, 5600K, FAN MAX, D.EXTENDER, VF ASSIGN SW1, VF ASSIGN SW2, SPIRIT LEVEL INDICATOR, FOCUS ASSIST INDICATOR, RET1 SW TOGGLE, RET2 SW TOGGLE, RET3 SW TOGGLE, CURSOR ALL OFF, FLAG	JN/SY models only. When HDLA is attached: OFF, EXTENDER, 5600K, FAN MAX, D.EXTENDER, FLAG <b>Note</b> When you turn D.EXTENDER ON or OFF, noise may be generated. This is not a malfunction.
		<b>OFF</b> , RETURN1 SW, RETURN2 SW, ENG, PROD, VF DETAIL, MIX VF, 5600K, FAN MAX, D.EXTENDER, VF ASSIGN SW1, VF ASSIGN SW2, SPIRIT LEVEL INDICATOR, FOCUS ASSIST INDICATOR, RET1 SW TOGGLE, RET2 SW TOGGLE, RET3 SW TOGGLE, CURSOR ALL OFF, FLAG	CE/E models only. When HDLA is attached: OFF, EXTENDER, 5600K, FAN MAX, D.EXTENDER, FLAG <b>Note</b> When you turn D.EXTENDER ON or OFF, noise may be generated. This is not a malfunction.
	VF ASSIGN	OFF, <b>VF ASSIGN SW1</b> , VF ASSIGN SW2	Displayed only when HDLA is attached.
	VF OUT SW	<b>VF OUT RGB</b> , FOCUS POSITION METER	Displayed only when HDLA is attached. (When FOCUS POSITION METER is set, VF OUT SW (R/G/B) can be used for registering/displaying Marker 1/2/3.)

OPERATION			
Page title PageNo.	Item	Settings	Description
<SWITCH ASSIGN2> 15 (U10)	LENS VTR S/S	OFF, RETURN1 SW, <b>RETURN2 SW</b> , INCOM1, INCOM2, VTR S/S JN/SY models only.	Assigns a function to the VTR START/STOP switch on the mounted lens.
		OFF, RETURN1 SW, <b>RETURN2 SW</b> , ENG, PROD, VTR S/S CE/E models only.	Assigns a function to the VTR START/STOP switch on the mounted lens.
FRONT RET1	FRONT RET1	OFF, <b>RETURN1 SW</b> , RETURN2 SW, INCOM1, INCOM2, D.EXTENDER JN/SY models only.	VTR S/S is available only when using the camcorder as a stand-alone device, and adds the REC signal to the SDI signal. Pressing this button repeatedly, toggles recording on/off. While recording, the tally lamp lights in red.
		OFF, <b>RETURN1 SW</b> , RETURN2 SW, ENG, PROD, D.EXTENDER CE/E models only.	
FRONT RET2	FRONT RET2	OFF, RETURN1 SW, <b>RETURN2 SW</b> , INCOM1, INCOM2, D.EXTENDER, VTR S/S JN/SY models only.	
		OFF, RETURN1 SW, <b>RETURN2 SW</b> , ENG, PROD, D.EXTENDER, VTR S/S CE/E models only.	
HANDLE SW1	HANDLE SW1	OFF, <b>RETURN1 SW</b> , RETURN2 SW, INCOM1, INCOM2, ZOOM(T), VTR S/S JN/SY models only.	
		OFF, <b>RETURN1 SW</b> , RETURN2 SW, ENG, PROD, ZOOM(T), VTR S/S CE/E models only.	
HANDLE SW2	HANDLE SW2	OFF, RETURN1 SW, RETURN2 SW, <b>INCOM1</b> , INCOM2, ZOOM(W) JN/SY models only.	
		OFF, RETURN1 SW, RETURN2 SW, <b>ENG</b> , PROD, ZOOM(W) CE/E models only.	
ZOOM SPEED	ZOOM SPEED	0 to 99, <b>20</b>	
HKCT INCOM MIC	HKCT INCOM MIC	OFF, <b>INCOM1</b> , INCOM2 JN/SY models only.	Assigns a function to the INTERCOM MIC switch on the HKC-T1500.
		OFF, <b>ENG</b> , PROD CE/E models only.	Assigns a function to the INTERCOM MIC switch on the HKC-T1500.

OPERATION			
Page title PageNo.	Item	Settings	Description
<EXT SWITCH> 16	RET CTRL CONNECTOR		
	RET1 Pin5:	OFF, <b>RETURN1 SW</b> , RETURN2 SW, RETURN3 SW, INCOM 1, INCOM 2, EXTENDER, D.EXTENDER, 5600K, VF DETAIL, SPIRIT LEVEL, FOCUS ASSIST, VF ASSIGN SW1, VF ASSIGN SW2, VTR S/S, TALLY R, TALLY G, TALLY Y	This function works when each pin of the RET CTRL connector contacts with GND (Pin3). TALLY R, G, Y are available only when using the camera as a standalone device, and make the tally lamp light. VTR S/S is available only when using the camera as a standalone device, and makes the R tally lamp light. VTR S/S signal is embedded in the video.
	RET2 Pin6:	OFF, RETURN1 SW, <b>RETURN2 SW</b> , RETURN3 SW, INCOM 1, INCOM 2, EXTENDER, D.EXTENDER, 5600K, VF DETAIL, SPIRIT LEVEL, FOCUS ASSIST, VF ASSIGN SW1, VF ASSIGN SW2, VTR S/S, TALLY R, TALLY G, TALLY Y	
	RET3 Pin4:	OFF, RETURN1 SW, RETURN2 SW, <b>RETURN3 SW</b> , INCOM 1, INCOM 2, EXTENDER, D.EXTENDER, 5600K, VF DETAIL, SPIRIT LEVEL, FOCUS ASSIST, VF ASSIGN SW1, VF ASSIGN SW2, VTR S/S, TALLY R, TALLY G, TALLY Y	
	INCOM1 Pin1:	OFF, RETURN1 SW, RETURN2 SW, RETURN3 SW, <b>INCOM 1</b> , INCOM 2, EXTENDER, D.EXTENDER, 5600K, VF DETAIL, SPIRIT LEVEL, FOCUS ASSIST, VF ASSIGN SW1, VF ASSIGN SW2, VTR S/S, TALLY R, TALLY G, TALLY Y	
	INCOM2 Pin2:	OFF, RETURN1 SW, RETURN2 SW, RETURN3 SW, INCOM 1, <b>INCOM 2</b> , EXTENDER, D.EXTENDER, 5600K, VF DETAIL, SPIRIT LEVEL, FOCUS ASSIST, VF ASSIGN SW1, VF ASSIGN SW2, VTR S/S, TALLY R, TALLY G, TALLY Y	
<RETURN> 17	RET1 SW SEL	CCU RET1, CCU RET2,	Varies based on the RET1 button setting.
	RET2 SW SEL	CCU RET3, CCU RET4	Varies based on the RET2 button setting.
	RET3 SW SEL	CCU RET1, CCU RET2, <b>CCU RET3</b> , CCU RET4	
	RET1 SW + RET2 SW	<b>RET1 SW</b> , RET3 SW	Changes operation when you press both the RET1 button and RET2 button at the same time. <b>RET1 SW</b> : The two buttons function as the RET1 button. <b>RET3 SW</b> : The two buttons function as the RET3 button.

<b>OPERATION</b>				
<b>Page title PageNo.</b>	<b>Item</b>	<b>Settings</b>	<b>Description</b>	
<HEADSET MIC> 18 (U11)	INTERCOM1	<b>DYNAMIC</b> , CARBON, MANUAL		
	LEVEL	-60 dB, -50 dB, -40 dB, -30 dB, -20 dB, ( <b>-60 dB</b> ), (-50 dB), (-40 dB), (-30 dB), (-20 dB)	Settings in ( ): With DYNAMIC or CARBON (cannot be changed)	
		-6, <b>0</b> , 6 dB	Input gain	
	POWER	ON, OFF, (ON), ( <b>OFF</b> )	Settings in ( ): With DYNAMIC or CARBON (cannot be changed)	
	UNBAL	ON, OFF, ( <b>ON</b> ), (OFF)	Settings in ( ): With CARBON (cannot be changed)	
	INTERCOM2	<b>DYNAMIC</b> , CARBON, MANUAL		
	LEVEL	-60 dB, -50 dB, -40 dB, -30 dB, -20 dB, ( <b>-60 dB</b> ), (-50 dB), (-40 dB), (-30 dB), (-20 dB)	Settings in ( ): With DYNAMIC or CARBON (cannot be changed)	
		-6, <b>0</b> , 6 dB	Input gain	
	POWER	ON, OFF, (ON), ( <b>OFF</b> )	Settings in ( ): With DYNAMIC or CARBON (cannot be changed)	
	UNBAL	<b>ON</b> , OFF, (ON), (OFF)	Settings in ( ): With CARBON (cannot be changed)	
	<INTERCOM1> 19	INTERCOM1 RECEIVE SELECT	<b>SEPARATE</b> , MIX	
		INTERCOM	---, <b>LEFT</b> , RIGHT, BOTH	JN/SY models only When ENG/PROD is set to MIX, ENG and PROD appears instead of this item (the setting values are same as this item).
ENG		---, <b>LEFT</b> , RIGHT, BOTH		
PROD		---, <b>LEFT</b> , RIGHT, BOTH		
PGM1		---, LEFT, <b>RIGHT</b> , BOTH		
PGM2		---, LEFT, <b>RIGHT</b> , BOTH		
TRACKER		---, <b>LEFT</b> , RIGHT, BOTH		
SIDE TONE		MU, 1 to 99, <b>50</b>		
INTERCOM1/2		<b>SEPARATE</b> , MIX		
ENG/PROD		<b>SEPARATE</b> , MIX	JN/SY models only	
<INTERCOM2> 20		INTERCOM2 RECEIVE SELECT	<b>SEPARATE</b> , MIX	
		INTERCOM	---, <b>LEFT</b> , RIGHT, BOTH	JN/SY models only When ENG/PROD is set to MIX, ENG and PROD appears instead of this item (the setting values are same as this item).
		ENG	---, <b>LEFT</b> , RIGHT, BOTH	
		PROD	---, <b>LEFT</b> , RIGHT, BOTH	
		PGM1	---, LEFT, <b>RIGHT</b> , BOTH	
	PGM2	---, LEFT, <b>RIGHT</b> , BOTH		
	TRACKER	---, LEFT, RIGHT, BOTH		
	SIDE TONE	MU, 1 to 99, <b>50</b>		
	INTERCOM1/2	<b>SEPARATE</b> , MIX		
	ENG/PROD	<b>SEPARATE</b> , MIX	JN/SY models only	

OPERATION			
Page title PageNo.	Item	Settings	Description
<TRACKER> 21	TRACKER RECEIVE SELECT	<b>SEPARATE</b> , MIX	
	INTERCOM	--- , <b>LEFT</b> , RIGHT, BOTH	JN/SY models only When ENG/PROD is set to MIX, ENG and PROD appears instead of this item (the setting values are same as this item).
	ENG	--- , <b>LEFT</b> , RIGHT, BOTH	
	PROD	--- , <b>LEFT</b> , RIGHT, BOTH	
	PGM1	--- , LEFT, <b>RIGHT</b> , BOTH	
	PGM2	--- , LEFT, <b>RIGHT</b> , BOTH	
	INPUT LEVEL	-20 dBu, <b>0 dBu</b> -6 dB, <b>0 dB</b> , 6 dB	
	OUTPUT LEVEL	L-CH <b>0 dBu</b> , -6 dBu, -12 dBu, -18 dBu, -20 dBu, -24 dBu R-CH	
<EARPHONE> 22	EARPHONE RECEIVE SELECT	<b>SEPARATE</b> , MIX	
	INTERCOM	--- , <b>LEFT</b> , RIGHT, BOTH	JN/SY models only When ENG/PROD is set to MIX, ENG and PROD appears instead of this item (the setting values are same as this item).
	ENG	--- , <b>LEFT</b> , RIGHT, BOTH	
	PROD	--- , <b>LEFT</b> , RIGHT, BOTH	
	PGM1	--- , LEFT, <b>RIGHT</b> , BOTH	
	PGM2	--- , LEFT, <b>RIGHT</b> , BOTH	
	TRACKER	--- , <b>LEFT</b> , RIGHT, BOTH	
<OPERATOR FILE> 23	READ (USB → CAM)	Execute via ENTER.	Reads the operator file from a USB drive.
	WRITE (CAM → USB)	Execute via ENTER.	Writes the current settings of the operator file items to a USB drive.
	PRESET	Execute via ENTER.	Sets the operator file items to the preset values in internal memory.
	FILE ID	alphanumerics (max.14 characters)	Enters a comment for the operator file to be written to a USB drive.  <i>See "To specify a character string" on page 28.</i>
	CAM CODE	Camera code	Display only
	DATE		Display only

# PAINT Menu

PAINT			
Page title PageNo.	Item	Settings	Description
<SW STATUS> P01	FLARE	<b>ON</b> , OFF	
	GAMMA	<b>ON</b> , OFF	
	BLK GAM	ON, <b>OFF</b>	
	KNEE	<b>ON</b> , OFF	
	WHT CLIP	<b>ON</b> , OFF	
	DETAIL	<b>ON</b> , OFF	
	LVL DEP	<b>ON</b> , OFF	
	SKIN DTL	ON, <b>OFF</b>	
	MATRIX	ON, <b>OFF</b>	
<VIDEO LEVEL> P02	WHITE	R/G/B: -99 to +99, <b>0</b>	R, G, B, and M (master) values can be independently set. (M cannot be set for WHITE.)
	BLACK	R/G/B/M: -99 to +99, <b>0</b>	
	FLARE	R/G/B/M: -99 to +99, <b>0</b>	
	GAMMA	R/G/B/M: -99 to +99, <b>0</b>	
	V MOD	R/G/B/M: -99 to +99, <b>0</b>	
	FLARE	<b>ON</b> , OFF	
	V MOD	<b>ON</b> , OFF	
	TEST	<b>OFF</b> , SAW, 10STEP	
<COLOR TEMP> P03	WHITE	R/G/B: -99 to +99, <b>0</b>	
	AUTO WHITE BALANCE	Execute via ENTER.	
	COLOR TEMP	0K to 65535K, <b>3200K</b>	
	BALANCE	-99 to +99, <b>0</b>	
	ATW	ON, <b>OFF</b>	
	SPEED	1, <b>2</b> , 3, 4, 5	
	MASTER	-3.0 to +12.0 dB, <b>0.0 dB</b>	
<GAMMA> P04	LEVEL	R/G/B/M: -99 to +99, <b>0</b>	R, G, B, and M (master) values can be independently set.
	COARSE	0.35 to 0.90 (0.05 steps), <b>0.45</b>	
	TABLE	<b>STANDARD</b> , HYPER	
		1, 2, 3, 4, <b>5</b> , 6, 7	With STANDARD selected
			1: equivalent to a camcorder 2: gain x4.5 3: gain x3.5 4: equivalent to SMPTE-240M 5: equivalent to ITU-R709 6: gain x5.0 7: x5.0-709
		1, 2, 3, <b>4</b>	With HYPER selected
			1: 325% to 100% 2: 460% to 100% 3: 325% to 109% 4: 460% to 109%
	GAMMA	<b>ON</b> , OFF	
TEST	<b>OFF</b> , SAW, 10STEP		
<BLACK GAMMA> P05	LEVEL	R/G/B/M: -99 to +99, <b>0</b>	R, G, B, and M (master) values can be independently set.
	RANGE	LOW, L.MID, H.MID, <b>HIGH</b>	
	TEST	ON, <b>OFF</b>	
	TEST	<b>OFF</b> , SAW, 10STEP	



<b>PAINT</b>			
<b>Page title PageNo.</b>	<b>Item</b>	<b>Settings</b>	<b>Description</b>
<SATURATION> P06	SATURATION	-99 to +99, <u>0</u> ON, <b>OFF</b>	
	LOW KEY SAT	-99 to +99, <u>0</u>	
	RANGE	LOW, L.MID, H.MID, <b>HIGH</b> ON, <b>OFF</b>	
	TEST	<b>OFF</b> , SAW, 10STEP	
<KNEE> P07	K POINT	R/G/B/M: -99 to +99, <u>0</u>	R, G, B, and M (master) values can be independently set. Absolute values are displayed in ABS mode except for M (master).
	K SLOPE	R/G/B/M: -99 to +99, <u>0</u>	
	KNEE	<b>ON</b> , OFF	
	KNEE MAX	ON, <b>OFF</b>	
	KNEE SAT	-99 to +99, <u>0</u> ON, <b>OFF</b>	
	AUTO KNEE	<b>OFF</b> , AUTO	
	POINT LIMIT	-99 to +99, <u>0</u>	Absolute value is displayed in ABS mode.
	SLOPE	-99 to +99, <u>0</u>	Absolute value is displayed in ABS mode.
	SOFT KNEE	ON, <b>OFF</b>	Gives a smooth curve for KNEE.
	RADIUS	<u>0</u> to 99	Adjusts the range of starting a smooth curve using SOFT KNEE.
<WHITE CLIP> P08	W CLIP	-99 to +99, <u>0</u> ON, OFF	
	ABS		Highlighted: ABS (Absolute) mode
<DETAIL 1> P09	DETAIL	<b>ON</b> , OFF	
	LEVEL	-99 to +99, <u>0</u>	Absolute value is displayed in ABS mode.
	LIMITER [M]	-99 to +99, <u>0</u>	
	LIMITER [WHT]	-99 to +99, <u>0</u>	Absolute value is displayed in ABS mode.
	LIMITER [BLK]	-99 to +99, <u>0</u>	Absolute value is displayed in ABS mode.
	CRISP	-99 to +99, <u>0</u>	Absolute value is displayed in ABS mode.
	LEVEL DEPEND	-99 to +99, <u>0</u> <b>ON</b> , OFF	Absolute value is displayed in ABS mode.
	ABS		Highlighted: ABS (Absolute) mode
<DETAIL 2> P10	H/V RATIO	-99 to +99, <u>0</u>	Absolute value is displayed in ABS mode.
	FREQ	-99 to +99, <u>0</u>	Absolute value is displayed in ABS mode.
	MIX RATIO	-99 to +99, <u>0</u>	Absolute value is displayed in ABS mode.
	KNEE APT	-99 to +99, <u>0</u> ON, <b>OFF</b>	Absolute value is displayed in ABS mode.
	DTL H/V MODE	<b>H/V</b> , V only	
	INDEPENDENT	ON, <b>OFF</b>	Selects whether to link to DETAIL. Displayed when <CAM MODE> is 4K/HDR MODE.
	ABS		Highlighted: ABS (Absolute) mode

<b>PAINT</b>			
<b>Page title PageNo.</b>	<b>Item</b>	<b>Settings</b>	<b>Description</b>
<HD DETAIL> P11 Displayed when <CAM MODE> is 4K/HDR MODE.	DETAIL	<b>ON</b> , OFF	
	LEVEL	-99 to +99, <b>0</b>	Absolute value is displayed in ABS mode.
	LIMITER [M]	-99 to +99, <b>0</b>	
	LIMITER [WHT]	-99 to +99, <b>0</b>	Absolute value is displayed in ABS mode.
	LIMITER [BLK]	-99 to +99, <b>0</b>	Absolute value is displayed in ABS mode.
	CRISP	-99 to +99, <b>0</b>	Absolute value is displayed in ABS mode.
	LEVEL DEPEND	-99 to +99, <b>0</b>	Absolute value is displayed in ABS mode.
		<b>ON</b> , OFF	
	H/V RATIO	-99 to +99, <b>0</b>	Absolute value is displayed in ABS mode.
	FREQ	-99 to +99, <b>0</b>	Absolute value is displayed in ABS mode.
	MIX RATIO	-99 to +99, <b>0</b>	Absolute value is displayed in ABS mode.
	KNEE APT	-99 to +99, <b>0</b>	Absolute value is displayed in ABS mode.
		<b>ON</b> , <b>OFF</b>	
	ABS		Highlighted: ABS (Absolute) mode
<4K DETAIL> P12 Displayed when <CAM MODE> is 4K/HDR MODE.	DETAIL	<b>ON</b> , OFF	
	LEVEL	-99 to +99, <b>0</b>	Absolute value is displayed in ABS mode.
	LIMITER [M]	-99 to +99, <b>0</b>	
	LIMITER [WHT]	-99 to +99, <b>0</b>	Absolute value is displayed in ABS mode.
	LIMITER [BLK]	-99 to +99, <b>0</b>	Absolute value is displayed in ABS mode.
	CRISP	-99 to +99, <b>0</b>	Absolute value is displayed in ABS mode.
	LEVEL DEPEND	-99 to +99, <b>0</b>	Absolute value is displayed in ABS mode.
		<b>ON</b> , OFF	
	H/V RATIO	-99 to +99, <b>0</b>	Absolute value is displayed in ABS mode.
	FREQ	-99 to +99, <b>0</b>	Absolute value is displayed in ABS mode.
	MIX RATIO	-99 to +99, <b>0</b>	Absolute value is displayed in ABS mode.
	KNEE APT	-99 to +99, <b>0</b>	Absolute value is displayed in ABS mode.
		<b>ON</b> , <b>OFF</b>	
	ABS		Highlighted: ABS (Absolute) mode
<SKIN DETAIL> P13	SKIN DTL	<b>ON</b> , <b>OFF</b>	
	SKIN GATE	<b>OFF</b> , 1, 2, 3, (MAT)	<b>1, 2, 3:</b> The skin gate function can be turned on for the specified channel only. <b>(MAT):</b> Displayed when GATE of <MULTI MATRIX> is ON.
	NATURAL SKINDTL	<b>OFF</b> , ON	
	ZOOM LINK	<b>OFF</b> , ON	
	TELE	0 to <b>99</b>	
	WIDE	<b>0</b> to 99	
	CH SW	1: (ON), 2/3: ON, <b>OFF</b>	Sets the skin tone detail function independently for each channel. (Channel 1 is always set to ON.)
	HUE	1/2/3: Execute via ENTER.	
	PHASE	1/2/3: <b>0</b> to 359	
	WIDTH	1/2/3: 0 to 90, <b>29</b>	Absolute values are indicated for LEVEL only in ABS mode.
	SAT	1/2/3: -99 to +99, <b>-89</b>	
	LEVEL	1/2/3: -99 to +99, <b>0</b>	
	Y LIMIT	1/2/3: <b>0</b> to 99	

PAINT			
Page title PageNo.	Item	Settings	Description
<USER MATRIX> P14	R-G	-99 to +99, <u>0</u>	
	R-B	-99 to +99, <u>0</u>	
	G-R	-99 to +99, <u>0</u>	
	G-B	-99 to +99, <u>0</u>	
	B-R	-99 to +99, <u>0</u>	
	B-G	-99 to +99, <u>0</u>	
	MATRIX	ON, <u>OFF</u>	
	PRESET	---, ON, OFF ---, SMPTE-240M, ITU-709, SMPTE-WIDE, NTSC, EBU, ITU- 601, CUSTOM1, CUSTOM2, CUSTOM3, CUSTOM4, CUSTOM5	
	USER	---, ON, OFF	
	MULTI	---, ON, OFF	
<MULTI MATRIX> P15	ADAPTIVE MATRIX	<u>OFF</u> , ON	
	LEVEL	0 to 7, <u>0</u>	
	PHASE	<u>0</u> , 23, 45, 68, 90, 113, 135, 158, 180, 203, 225, 248, 270, 293, 315, 338	Selects an axis (angle) at PHASE for which the multimatrix adjustment to be made, and set HUE and SAT. (HUE and SAT can be adjusted independently for 16 axes.)
	HUE	-99 to +99, <u>0</u>	
	SAT	-99 to +99, <u>0</u>	
	ALL CLEAR	Execute via ENTER.	
	GATE	ON, <u>OFF</u> , (1), (2), (3)	(1), (2), (3): Displayed when SKIN GATE of <SKIN DETAIL> is ON.
	MATRIX	ON, <u>OFF</u>	
	PRESET	---, ON, OFF ---, SMPTE-240M, ITU-709, SMPTE-WIDE, NTSC, EBU, ITU- 601, CUSTOM1, CUSTOM2, CUSTOM3, CUSTOM4, CUSTOM5	
	MULTI	---, ON, OFF	
<SHUTTER> P16	SHUTTER	ON, <u>OFF</u> , (ON), (OFF)	Settings in ( ): When a remote control unit/panel or a CCU is not connected (cannot be changed)
		59.94i: <u>1/100</u> , 1/125, 1/250, 1/500, 1/1000, 1/2000 50i: 1/60, <u>1/125</u> , 1/250, 1/500, 1/1000, 1/2000 59.94P: <u>1/100</u> , 1/125, 1/250, 1/500, 1/1000, 1/2000 50P: 1/60, <u>1/125</u> , 1/250, 1/500, 1/1000, 1/2000	Step shutter selection
	ECS FREQ	59.94i: <u>60.00</u> to 4300 Hz 50i: 50.00 to 4700 Hz 59.94P: 59.96 to 4600 Hz 50P: 50.03 to 4600 Hz	
<FLICKER REDUCTION> P17	REDUCTION	ON, <u>OFF</u>	<b>Note</b>
	POWER LINE FREQUENCY	<u>50</u> , 60	When you turn REDUCTION ON or OFF, noise may be generated. This is not a malfunction.

<b>PAINT</b>			
<b>Page title PageNo.</b>	<b>Item</b>	<b>Settings</b>	<b>Description</b>
<HDR OPERATION> P18 Displayed when <CAM MODE> is 4K/HDR MODE.	HDR MODE	OFF, LIVE HDR	Displays the CCU setting.
	SDR GAIN	<b>0.0</b> to -15 dB	Enabled only when LIVE HDR is selected. Gain setting applied to the SDR output.
	HDR CONTRAST	100 to 560 %	Enabled only when LIVE HDR is selected. HDR output contrast ensured by setting SDR GAIN (display only).
	HDR BLACK OFFSET	-99.9 to +99.9, <b>0</b>	Enabled only when LIVE HDR is selected. HDR output black offset
	HDR KNEE	<b>OFF</b> , ON	Enabled only when LIVE HDR is selected.
	POINT	-99 to +99, <b>0</b>	KNEE setting applied for HDR
	SLOPE	-99 to +99, <b>0</b>	
	HDR WHITE CLIP	<b>OFF</b> , ON	
	LEVEL	-99 to 99, <b>0</b>	
	<SCENE FILE> P19	1	
2			When storing a file in camera memory, specify the number before executing STORE.
3			When reading, only specify the number.
4			
5			
STORE		Execute via ENTER.	
STANDARD		Execute via ENTER.	Reads the standard paint data.
READ (USB → CAM)		Execute via ENTER.	Loads 32 scene files from a USB drive to internal memory.
WRITE (CAM → USB)		Execute via ENTER.	Writes 32 scene files in the camera's memory to a USB drive.
FILE ID		Max.14 characters	Enters a comment for the scene files to be written to a USB drive.  <i>See "To specify a character string" on page 28.</i>
CAM CODE		Camera code	Display only
DATE		Date	Display only
DISSOLVE		<b>OFF</b> , ON	Switching a scene file seamlessly.
SPEED		0.2 to 2.8 (0.2 step), 3 to 10 (1 step), <b>0.2</b>	

# MAINTENANCE Menu

MAINTENANCE			
Page title PageNo.	Item	Settings	Description
<AUTO SETUP> M01	AUTO BLACK	Execute via ENTER.	
	AUTO WHITE	Execute via ENTER.	
	AUTO LEVEL	Execute via ENTER.	
	AUTO WHITE SHADING	Execute via ENTER.	
	AUTO BLACK SHADING	Execute via ENTER.	
	TEST	<b>OFF</b> , SAW, 10STEP	
<WHITE SHADING> M02	V SAW	R/G/B: -99 to +99, <b>0</b>	R, G, and B values can be independently set.
	V PARA	R/G/B: -99 to +99, <b>0</b>	
	H SAW	R/G/B: -99 to +99, <b>0</b>	
	H PARA	R/G/B: -99 to +99, <b>0</b>	
	WHITE	R/G/B: -99 to +99, <b>0</b>	
	AUTO WHITE SHADING	Execute by ENTER.	
	WHITE SHAD MODE	RGB, <b>RB</b>	
<BLACK SHADING> M03	V SAW	R/G/B: -99 to +99, <b>0</b>	R, G, and B values can be independently set.
	V PARA	R/G/B: -99 to +99, <b>0</b>	M (master) value can also be set for BLACK.
	H SAW	R/G/B: -99 to +99, <b>0</b>	
	H PARA	R/G/B: -99 to +99, <b>0</b>	
	BLK SET	R/G/B: -99 to +99, <b>0</b>	
	BLACK	R/G/B/M: -99 to +99, <b>0</b>	
	MASTER GAIN	-6, -3, <b>0</b> , 3, 6, 9, 12 dB	
	AUTO BLACK SHADING	Execute via ENTER.	
	2D BLACK SHADING	<b>ON</b> , OFF	
<OHB MATRIX> M04	PHASE	<b>0</b> , 23, 45, 68, 90, 113, 135, 158, 180, 203, 225, 248, 270, 293, 315, 338	Selects an axis (angle) at PHASE for which the OHB matrix adjustment is to be made, and set HUE and SAT. (HUE and SAT can be adjusted independently for 16 axes.)
	HUE	-99 to +99, <b>0</b>	
	SAT	-99 to +99, <b>0</b>	
	ALL CLEAR	Execute via ENTER.	Clears the HUE and SAT values for all PHASE settings.
	OHB MATRIX	ON, <b>OFF</b>	
	MATRIX	ON, <b>OFF</b>	

**MAINTENANCE**

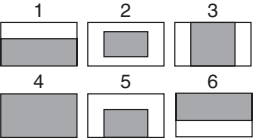
Page title PageNo.	Item	Settings	Description
<AUTO IRIS> M05	AUTO IRIS	ON, <b>OFF</b> , (ON), (OFF)	Settings in ( ): When a remote control unit/panel or a CCU is not connected (cannot be changed)
	WINDOW	<b>1</b> , 2, 3, 4, 5, 6	Selects the auto iris windows:   The shaded parts indicate the area where light detection occurs.
	OVERRIDE	-99 to 99, <b>0</b> , ---	Sets the override to temporarily change the reference value for brightness of the automatic iris level in the range of ±2 steps: -99: Two steps to fully closed iris. 99: Two steps to fully opened iris. --- : OFF The setting returns to “ --- ” when the power is turned off.
	IRIS LEVEL	-99 to +99, <b>0</b>	±4 steps
	APL RATIO	-99 to +99, <b>65</b>	
	IRIS GAIN	-99 to +99, <b>0</b>	
	IRIS CLOSE	ON, <b>OFF</b>	
	<LENS1> M06	F NO. DISP	<b>CONTROL</b> , RETURN
AF DISPLAY		ON, <b>OFF</b> , OFF(EFFECT), OFF(ASSIST IND)	<b>OFF(EFFECT)</b> : Displayed when EFFECT of <VF MARKER> is ON. <b>OFF(ASSIST IND)</b> : Displayed when INDICATOR of <FOCUS ASSIST> is ON.
ALAC		<b>AUTO</b> , OFF	With AUTO selected, the status is displayed at the right. <b>(ACTIVE)</b> : Compensation is in progress. <b>(WAIT)</b> : Waiting for completion of lens initialization. <b>(STOP)</b> : Compensation is turned off for a non-applicable lens.
F DROP COMP		<b>OFF</b> , ON, (OFF)	Turns F drop compensation on/off. During compensation, the compensation gain is displayed on the right. (OFF): For when a serial lens is not attached.
MAX GAIN		<b>0.0</b> to 24 dB	Maximum compensation value
DROP POINT		0 to 99, <b>50</b>	Compensation start point
ROUNDNESS		<b>0.0</b> to 12 dB	Roundness of the compensation curve.
STORE LENS FILE		Execute using ENTER.	Saves settings to a lens file.

MAINTENANCE			
Page title PageNo.	Item	Settings	Description
<LENS2> M07	REMOTE CONTROL	<b>OFF</b> , ON, (OFF)	Lens remote control from MSU/RCP on/off setting. Same function as the Active button on the Zoom/ Focus Control screen of the MSU/RCP. (OFF): When lens is not supported
	CONTROL MODE	<b>ZOOM&amp;FOCUS</b> , FOCUS, FOLLOW FOCUS	<b>ZOOM &amp; FOCUS</b> : Control ZOOM and FOCUS from an MSU/RCP (control by lens demand is not supported). <b>FOCUS</b> : Control FOCUS from an MSU/RCP. ZOOM is controlled by lens demand. <b>FOLLOW FOCUS</b> : FOCUS is controlled by lens demand, but can be adjusted (offset fine adjustment) from an MSU/RCP. ZOOM is controlled by lens demand.
	<b>Note</b>		
	Settings other than FOLLOW FOCUS cannot be modified when the offset is not 0 and REMOTE CONTROL is OFF. To change settings, set REMOTE CONTROL to ON.		
FOLLOW FOCUS			
	OFFSET ADJUST SENS	1, 2, <b>3</b> , 4, 5	Sets the sensitivity of superimposing the offset of the MSU.
	OFFSET CANCEL GAIN	1, 2, <b>3</b> , 4, 5	Sets the sensitivity of canceling the offset on the demand side.
<MIC GAIN> M08	MIC1	20, 30, 40, 50, <b>60</b> dB	Can be modified only in standalone operation.
	MIC2	20, 30, 40, 50, <b>60</b> dB	
<CALL/TALLY> M09	CCU CALL	OFF, <b>ON</b>	Selects whether TALLY lights for CALL signal.
	CAM CALL	<b>OFF</b> , ON	
	UP TALLY BRIGHTNESS		
	TALLY	0 to 100, <b>50</b>	
	NUMBER	0 to 100, <b>50</b>	
	NUMBER DISPLAY	<b>AUTO</b> , OFF, ON	
	CAMERA NUMBER	---, 1 to 96	
	CCU LINK	<b>OFF</b> , ON	ON sets CAMERA NUMBER to the same number as the CCU number.
	TALLY GUARD		
	EXTENDER	<b>OFF</b> , ON	Selects whether to prevent changes while TALLY is lit.
	FILTER DISC	<b>OFF</b> , ON	
<OUTPUT FORMAT> M10 (U12)	CURRENT	1080: 59.94i, 50i 720: 59.94P, 50P	Displays the current format.
<TEST OUT> M11 (U13)	OUTPUT	SD-SYNC, HD-SYNC, VF, <b>VBS</b>	
	VBS-OUT		
	CHARACTER	ON, <b>OFF</b>	OUTPUT is displayed during VBS.
	GAIN	-99 to +99, <b>0</b>	
	CHROMA	-99 to +99, <b>0</b>	
	SYNC-OUT		
	V-PHASE	-999 to +999, <b>0</b>	OUTPUT is displayed during SD-SYNC and HD- SYNC.
	H-PHASE	-999 to +999, <b>0</b>	
	DOWN CONVERTER		
	SELECT	<b>MAIN</b> , RET, VF	OUTPUT is displayed for VBS.
	ASPECT	<b>SQ</b> , EC	

MAINTENANCE			
Page title PageNo.	Item	Settings	Description
<SDI OUT> M12 (U14)	SDI-MONI OUT	MAIN, <b><u>VE</u></b> , RET, SD-SDI, OFF	
	CHARACTER	ON, <b><u>OFF</u></b>	
	EMB AUDIO	<b><u>OFF</u></b> , MIC, PGM	
	DOWN CONVERTER		SDI-MONI OUT is displayed for SD-SDI.
	SELECT	<b><u>MAIN</u></b> , RET, VF	
	ASPECT	<b><u>SQ</u></b> , EC	
<TRUNK> M13	TRUNK	<b><u>ON</u></b> , OFF	
	INTERFACE	<b><u>232c</u></b> , 422A	
	AUX REMOTE		Display only
<GENLOCK> M14	REFERENCE	Condition of synchronisation	Display only
	GENLOCK	<b><u>ENABLE</u></b> , DISABLE	Displayed only when no CCU connected.
	STATUS		
	FORMAT		
	PHASE		
	V	-1024 to 1023, <b><u>0</u></b>	
	H	-1700 to 1700, <b><u>0</u></b>	
<DATE> M15	DATE/TIME	2000 to 2099 / 01 to 12 / 00 to 31, 00 to 23 : 00 to 59	
	DATE FORMAT	1 Y/Mn/D, 2 Mn/D, 3 D/M/Y, 4 D/M, <b><u>5 M/D/Y</u></b> , 6 M/D	<b>Y</b> : Year <b>Mn</b> : Month (numeric) <b>M</b> : Month (character string) <b>D</b> : Day
<BATTERY ALARM> M16	BEFORE END	<b><u>11.5</u></b> to 17.0 V	
	END	<b><u>11.0</u></b> to 11.5 V	
<OTHERS> M17	FAN MODE	OFF, <b><u>AUTO1</u></b> , AUTO2, MIN, MAX	<b>AUTO1</b> : Normal rotation <b>AUTO2</b> : Slow rotation
	CAM BARS	ON, <b><u>OFF</u></b>	
	WHITE SETUP MODE	AWB, <b><u>A.LVL</u></b>	
	STANDALONE SW DISABLE	<b><u>OFF</u></b> , ON	When set to ON, disables operation of the unit's switches, such as the WHITE BAL switch, even when a CCU, or control panel is not connected.
<OPTION KEY> M18	READ (USB → CAM)	Execute via ENTER.	Reads the install key from a USB drive.
	EFFECTIVE FUNCTION	USER GAMMA, 4:4:4 FORMAT, PsF FORMAT, 1080P FORMAT	Displayed only when an option has been installed.
<CAM MODE> M19	CURRENT	NORMAL, 4K/HDR MODE (DOWNCONV INVALID)	Displays the current CAM MODE setting.
	CHANGE	4K/HDR MODE (DOWNCONV INVALID), NORMAL	Switches the CAM MODE setting.

**Note**

When <CAM MODE> is set to 4K/HDR MODE, DOWN CONVERTER is not available.  
Only the CHARACTER information is displayed when <CAM MODE> is set to 4K/HDR MODE and SD-SDI or VBS is selected.



## FILE Menu

Five types of files can be used for easy adjustments of the camera; Operator, Reference, Scene, OHB, and Lens. You can store the items set with the OPERATION menu and customized USER menu in the Operator file.

*For the specific items included in these files, refer to the Maintenance Manual.*

FILE			
Page title PageNo.	Item	Settings	Description
<OPERATOR FILE> F01	READ (USB → CAM)	Execute via ENTER.	Reads the operator file from a USB drive.
	WRITE (CAM → USB)	Execute via ENTER.	Writes the current settings of the operator file items to a USB drive.
	PRESET	Execute via ENTER.	Sets the operator file items to the preset values in internal memory.
	STORE PRESET FILE	Execute via ENTER.	Stores the current settings of the operator file items in the operator file in internal memory.
	FILE ID	Max.14 characters	Enters a comment for the operator file to be written to a USB drive. <i>See "To specify a character string" on page 28.</i>
	CAM CODE	Camera code	Display only
	DATE	Date	Display only
	<SCENE FILE> F02	1	
2			When storing a file in camera memory, specify the number before executing STORE.
3			When reading, only specify the number.
4			
5			
STORE		Execute via ENTER.	
STANDARD		Execute via ENTER.	Reads the standard paint data.
READ (USB → CAM)		Execute via ENTER.	Loads 32 scene files from a USB drive to internal memory.
WRITE (CAM → USB)		Execute via ENTER.	Writes 32 scene files in the camera's memory to a USB drive.
FILE ID		Max.14 characters	Enters a comment for the scene files to be written to a USB drive. <i>See "To specify a character string" on page 28.</i>
CAM CODE		Camera code	Display only
DATE		Date	Display only
DISSOLVE		<b>OFF</b> , ON	Switching a scene file seamlessly.
SPEED		0.2 to 2.8 (0.2 steps), 3 to 10 (1 steps), <b>0.2</b>	
<REFERENCE> F03	STORE FILE	Execute via ENTER.	Stores the current settings of the reference file items in the reference file in internal memory.
	STANDARD	Execute via ENTER.	Reads the standard values in the reference file in internal memory.
	ALL PRESET	Execute via ENTER.	Resumes the factory-preset reference file.
	READ (USB → CAM)	Execute via ENTER.	Loads a reference file from a USB drive.
	WRITE (CAM → USB)	Execute via ENTER.	Writes the current settings of the reference file items as a reference file to a USB drive.
	FILE ID	Max.14 characters	Enters a comment for the reference file to be written to a USB drive. <i>See "To specify a character string" on page 28.</i>
	CAM CODE	Camera code	Display only
	DATE	Date	Display only

FILE			
Page title PageNo.	Item	Settings	Description
<USER GAMMA> F04	READ (USB → CAM)	Execute via ENTER.	Reads the user gamma file from a USB drive.
	PRESET	Execute via ENTER.	Sets the user gamma file items to the preset values in internal memory.
	FILE ID	Max.14 characters	Enters a comment for the user gamma file to be written to a USB drive. <i>See "To specify a character string" on page 28.</i>
	CAM CODE	Camera code	Display only
	DATE	Date	Display only
<LENS FILE> F05	STORE FILE	Execute via ENTER.	The center marker is not included.
	No.	1 to 17, <b>1</b>	<b>1 to 16</b> : When using a non-serial lens (When using a large lens, this setting depends on the internal setting of the lens.) <b>17</b> : When using a serial lens
	NAME		Changeable only when using a non-serial lens.
	F NO	F1.0 to F3.4, <b>F1.7</b>	Changeable only when using a non-serial lens.
	CENTER MARKER		Sets and stores the center marker position:
	H POS	-20 to +20, <b>0</b>	<b>H POS</b> : Increasing the value moves the position to the right.
	V POS	-20 to +20, <b>0</b>	<b>V POS</b> : Increasing the value moves the position downwards.
<OHB FILE> F06	STORE FILE	Execute via ENTER.	Stores the offset values of items specific to the CCD. (No repeated store operation is necessary even if the CCD is reattached)
<MATRIX FILE> F07	CUSTOM PRESET MATRIX		Stores and reads preset files: When storing a preset file in camera memory, specify the file number.
	1		
	2		
	3		
	4		
	5		
	STORE FILE	Execute via ENTER.	
	CLEAR ALL	Execute via ENTER.	Clears all the files.
	READ (USB → CAM)	Execute via ENTER.	Loads five preset files from a USB drive to internal memory.
	WRITE (CAM → USB)	Execute via ENTER.	Writes five preset files in the camera's memory to a USB drive.
	FILE ID	Max.14 characters	Enters a comment for the preset files to be written to a USB drive. <i>See "To specify a character string" on page 28.</i>
	CAM CODE	Camera code	Display only
DATE	Date	Display only	

FILE			
Page title PageNo.	Item	Settings	Description
<BOX CURSOR FILE> F08	1:		Selects BOX CURSOR FILE and enters a BOX CURSOR FILE name.
	2:		Sets the cursor to the left of the number when you select BOX CURSOR FILE.
	3:		
	4:		Sets the cursor to the right of the number when you enter a BOX CURSOR FILE name.
	5:		
			<i>See "To specify a character string" on page 28.</i>
	STORE		Stores a BOX CURSOR FILE name in the camera.
	READ (USB → CAM)		Transfers BOX CURSOR FILE from a USB drive to the camera.
	WRITE (CAM → USB)		Transfers BOX CURSOR FILE from the camera to a USB drive.
<FILE CLEAR> F09	PRESET OPERATOR	Execute via ENTER.	
	REFERENCE (ALL)	Execute via ENTER.	
	10 SEC CLEAR	ON, <b>OFF</b>	Sets the function to clear the selected menu item to ON/OFF.  <i>See "To return a menu item to its standard value" on page 28.</i>
	OHB WHITE SHADE (ALL)	Execute via ENTER.	
	OHB BLACK SHADE	Execute via ENTER.	
	OHB ND OFFSET	Execute via ENTER.	
	OHB MATRIX	Execute via ENTER.	

## DIAGNOSIS Menu

This menu is only for viewing and camera settings cannot be made using this menu.

However, some items set the conditions for viewing.

DIAGNOSIS			
Page title PageNo.	Item	Indication	Description
<OPTICAL LEVEL> D01	CCU → CAM	GREEN, YELLOW, RED, NG, NO SIGNAL	Displayed only when a CCU is connected.
	CAM → CCU	GREEN, YELLOW, RED, NG, NO SIGNAL	Displayed only when a CCU is connected.
	CABLE LENGTH	x.x km	Displays the camera cable length. (Displayed only when a CCU is connected.)
<BOARD STATUS> D02	OHB	OK, NG	
	DPR	OK, NG	
	SY	OK, NG	
	PS	OK, NG	
	SDI	OK, NG	
	HOURS METER	xxxx H	Displays the total working time.
<ROM VERSION> D03 (U15)	CAMERA APP	Vx.xx	
	OS	Vx.xx	
	PANEL	Vx.xx	Displayed only when HDLA is attached.
	HKCT	Vx.xx	Displayed only when HKC-T1500 is installed.
	TG	Vx.xx	
	SY	Vx.xx	
	DPR1	Vx.xx	
	DPR2	Vx.xx	
	DPR3	Vx.xx	
	SDI	Vx.xx	
<SERIAL NO.> D04	MODEL	HDC1700	
	NO.	xxxxxxx	
	EFFECTIVE FUNCTION		Displayed if any option is installed.
<POWER SUPPLY STATUS> D05	CAM INPUT VOLTAGE	0% to 100%, 100% OVER	Displays the ratio of the input voltage for a camera to the output voltage for a CCU.
	CAM CONSUMPTION	xx.x A	Displays camera current consumption.
	CABLE LENGTH	x.x km	Displays the cable length that a CCU measured. (Displayed only when a CCU is connected.)

### Note

This display has a margin of error for the display of the electric supply state of a camera. Use only as a guide.

---

# Appendix

---

## Precautions

### Note on laser beams

Laser beams may damage the CCDs. If you shoot a scene that includes a laser beam, be careful not to let a laser beam become directed into the lens of the camera.

### Do not subject to severe shocks

Damage to the case or internal components may result.

### When finished using

Set the power switch to OFF.

### Operation and storage environment

Store in a level place with air conditioning.

If the unit gets wet, make sure it is completely dry before storage.

Avoid use or storage in the following places:

- Extremely hot or cold places
- Places with high humidity
- Places with strong vibration
- Near strong magnetic fields
- In places where it receives much direct sunlight, or near heating equipment

### Condensation

If you move the camera from a very cold place to a warm place, or use it in a damp location, condensation may form on the lens or inside the camera.

The camera has no built-in condensation indicator. If you find condensation on the body or lens, switch the camera off and wait for the condensation to disappear for about one hour.

### Phenomena Specific to CCD Image Sensors

The following phenomena that may appear in images are specific to CCD (Charge Coupled Device) image sensors. They do not indicate malfunctions.

### White flecks

Although the CCD image sensors are produced with high-precision technologies, fine white flecks may be generated on the screen in rare cases, caused by cosmic rays.

This is related to the principle of CCD image sensors and is not a malfunction.

The white flecks especially tend to be seen

- when operating at a high environmental temperature
- when you have raised the master gain (sensitivity)

This product has a compensation function and the problem may be alleviated by automatic black balance adjustment (see page 17).

### Smear

When an extremely bright object, such as a strong spotlight or flashlight, is being shot, vertical tails may be produced on the screen, or the image may be distorted.

### Aliasing

When fine patterns, stripes, or lines are shot, they may appear jagged or flicker.

### To prevent electromagnetic interference from portable communications devices

The use of portable telephones and other communications devices near this camera can result in malfunctions and interference with audio and video signals.

It is recommended that the portable communications devices near this camera be powered off.

---

## Error Messages

If a problem occurs during operation, a warning message is displayed.

### Note

To display a message, set the DISPLAY switch to DISPLAY or MENU.

Message	Meaning
TEMP WARNING	The internal temperature is abnormally high.
FAN STOP	The built-in fan is not rotating properly.
SET CORRECT SYSTEM DATE	The time/date of the internal clock have not been set.
OHB BLOCK NG!	A problem is detected in the optical block.
MSU RPN BUSY	RPN compensation was attempted using the camera menu while being operated from an external device. Consult Sony service personnel.
VF RPN BUSY	RPN compensation was attempted from an external device while being operated using the camera menu. Consult Sony service personnel.
NO USB FLASH DRIVE	A USB drive operation was attempted with no USB drive connected.
USB FLASH DRIVE ERROR	An error occurred during access to a USB drive.
FORMAT ERROR!	A USB drive operation was attempted with an unformatted USB drive.
WRITE PROTECTED	File writing was attempted with a write-protected USB drive.
FILE ERROR	An error occurred while reading a file from a USB drive.

Message	Meaning
OTHER MODEL'S FILE	You attempted to read a file of other models having no compatibility.
FILE NOT FOUND	The file you attempted to read does not exist in the USB drive.

---

## Using a USB Drive

You can connect a USB drive to the USB connector to save and load the settings data file.

The following Sony USB drives are recommended. (As of April 2013)

Series	Product
Micro Vault P	USM32GP, USM16GP
Micro Vault M	USM32GM, USM16GM, USM8GM, USM4GM
Micro Vault R	USM32GR, USM16GR, USM8GR, USM4GR
Micro Vault Q	USM64GQ, USM32GQ, USM16GQ, USM8GQ

### Notes

- USB drives other than those recommended may not be recognized when connected to the USB connector.
- USB drives must be formatted with the FAT16 or FAT32 file system. Recommended Sony USB drives are preformatted, and can be used without any prior setup.

# Specifications

## General

Power requirements	AC 240 V, 1.4 A (max.) DC 180 V, 1.0 A (max.) DC 12 V, 7 A (max.)
Operating temperature	-20°C to +45°C (-4°F to +113°F)
Storage temperature	-20°C to +60°C (-4°F to +140°F)
Mass	Approx. 4.5 kg (9 lb 15 oz) (Unit only)
Dimensions	See <i>page 65</i> .

## Imager

Imager	2/3-type Progressive Scan CCD
Method	3-CCD, RGB
Effective resolution	1920 (horizontal) × 1080 (vertical)

## Electrical characteristics

Sensitivity	F10.0 with 1080/59.94i F11.0 with 1080/50i (at 2000 lx with 89.9% reflectivity)
Image S/N	Typical -60 dB
Horizontal resolution	1000 TV lines (at center of screen) 5% or higher modulation
Geometric distortion	Negligible (not including lens distortion)

## Optical system specifications

Spectral system	F1.4 prism
Built-in filters	1: clear 2: 1/4ND 3: 1/16ND 4: 1/64ND 5: cross filter

## Input/output connectors

CCU	Optical/electrical multi-connector (1)
LENS	12-pin (1)
VF	20-pin (1)
MIC 1 IN	XLR 3-pin, female (1)
AUDIO IN CH1, CH2	XLR 3-pin, female (1 each) AUDIO switch for MIC: -60 dBu (can be selected up to -20 dBu by menu or HDCU1700 operations), balanced AUDIO switch for LINE: 0 dBu, balanced
INTERCOM 1, INTERCOM 2	XLR 5-pin, female (1 each)
EARPHONE	Stereo minijack (1)
DC IN	XLR 4-pin (1), DC 10.5 V to 17 V
DC OUT	4-pin (1), DC 10.5 V to 17 V, max. 0.5 A (This may be limited by the imposed load or inputs.)
SDI-MONI	BNC-type (1)
TEST OUT	BNC-type (1)
PROMPTER/ GENLOCK	BNC-type (1), 1 Vp-p, 75 ohms
RET CTRL	6-pin (1)

REMOTE	8-pin (1)
TRACKER	10-pin (1)
CRANE	12-pin (1)
USB	USB 2.0 Type A 4-pin (1) (for connecting USB drive)

## Supplied accessories

Operation guide (1)
Operation manual (CD-ROM) (1)
Cable clamp belt (1 set)
Camera number label (1)
Screws (+B3×8) (2)

Design and specifications are subject to change without notice.

## Optional Accessories/Related Equipment

### Optional Accessories

HD Electronic Viewfinder	HDVF-20A (2-type, monochrome) HDVF-200 (2-type, monochrome) HDVF-EL20 (0.7-type, color) HDVF-EL30 (0.7-type, color) HDVF-EL75 (7.4-type, color) HDVF-L750 (7-type, color) HDVF-L770 (7-type, color)
Large Lens Adaptor	HDLA1500/1505
Large Viewfinder Adaptor	HDLA1507
CCD Block Adaptor	HKC-T1500
Microphone Holder	CAC-12
Return Video Selector	CAC-6
Viewfinder Rotation Bracket	BKW-401
Dual Optical Filter Unit	HKC-DF20
Tripod Attachment	VCT-14
Low-repulsion Shoulder Pad	A-8286-346-A
Camera Operating Software	HZC-PSF20/PSF20M/PSF20W HZC-PRV20/PRV20M/PRV20W HZC-UG444/UG444M/UG444W

### Related Equipment

HDCU1700 HD Camera Control Unit
RCP-1000 series Remote Control Panel
MSU-1000 series Master Setup Unit
CNU-700 Camera Command Network Unit
HZC-CSM10 Camera System Management Software
CNA-1 Camera Control Network Adaptor

**Note**

Always verify that the unit is operating properly before use. SONY WILL NOT BE LIABLE FOR DAMAGES OF ANY KIND INCLUDING, BUT NOT LIMITED TO, COMPENSATION OR REIMBURSEMENT ON ACCOUNT OF THE LOSS OF PRESENT OR PROSPECTIVE PROFITS DUE TO FAILURE OF THIS UNIT, EITHER DURING THE WARRANTY PERIOD OR AFTER EXPIRATION OF THE WARRANTY, OR FOR ANY OTHER REASON WHATSOEVER.



# Dimensions

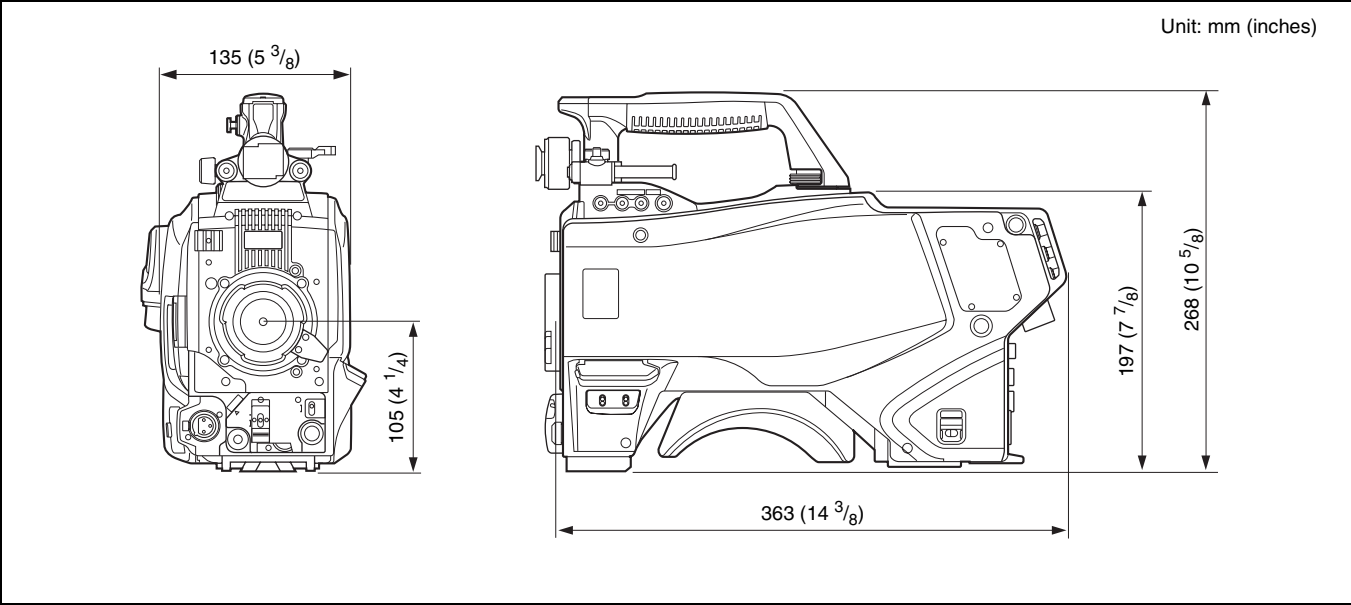

Sony Corporation